

# INSTALLATION INSTRUCTIONS

## ⚠ WARNING

Improper installation, adjustment, alteration, service or maintenance can cause property damage, personal injury or loss of life. Installation and service must be performed by a qualified installer, service agency or the gas supplier

**RETAIN THESE INSTRUCTIONS FOR FUTURE REFERENCE**

### Table Of Contents

|                                 |        |
|---------------------------------|--------|
| Dimensions .....                | Page 2 |
| Shipping and Packing List ..... | Page 3 |
| General .....                   | Page 3 |
| Requirements .....              | Page 3 |
| Unit Support .....              | Page 4 |
| Duct Connection .....           | Page 5 |
| Rigging Unit For Lifting .....  | Page 5 |
| Horizontal Air Discharge .....  | Page 6 |
| Condensate Drains .....         | Page 6 |

**KHA024 (2 TON)**  
**KHA030 (2-1/2 TON)**  
**KHA036 (3 TON)**  
**KHA048 (4 TON)**  
**KHA060 (5 TON)**  
**KHA072 (6 TON)**

**HEAT PUMP PACKAGED UNITS**  
 506002-01  
 4/2012  
 Supersedes 11/2011

|  |         |
|--|---------|
| Electrical Connections .....           | Page 8  |
| Blower Operation and Adjustments ..... | Page 10 |
| Start-Up .....                         | Page 18 |
| Defrost Control Board .....            | Page 21 |
| Service .....                          | Page 21 |

## KHA024, 030, 036, 048, 060, 072 PARTS ARRANGEMENT

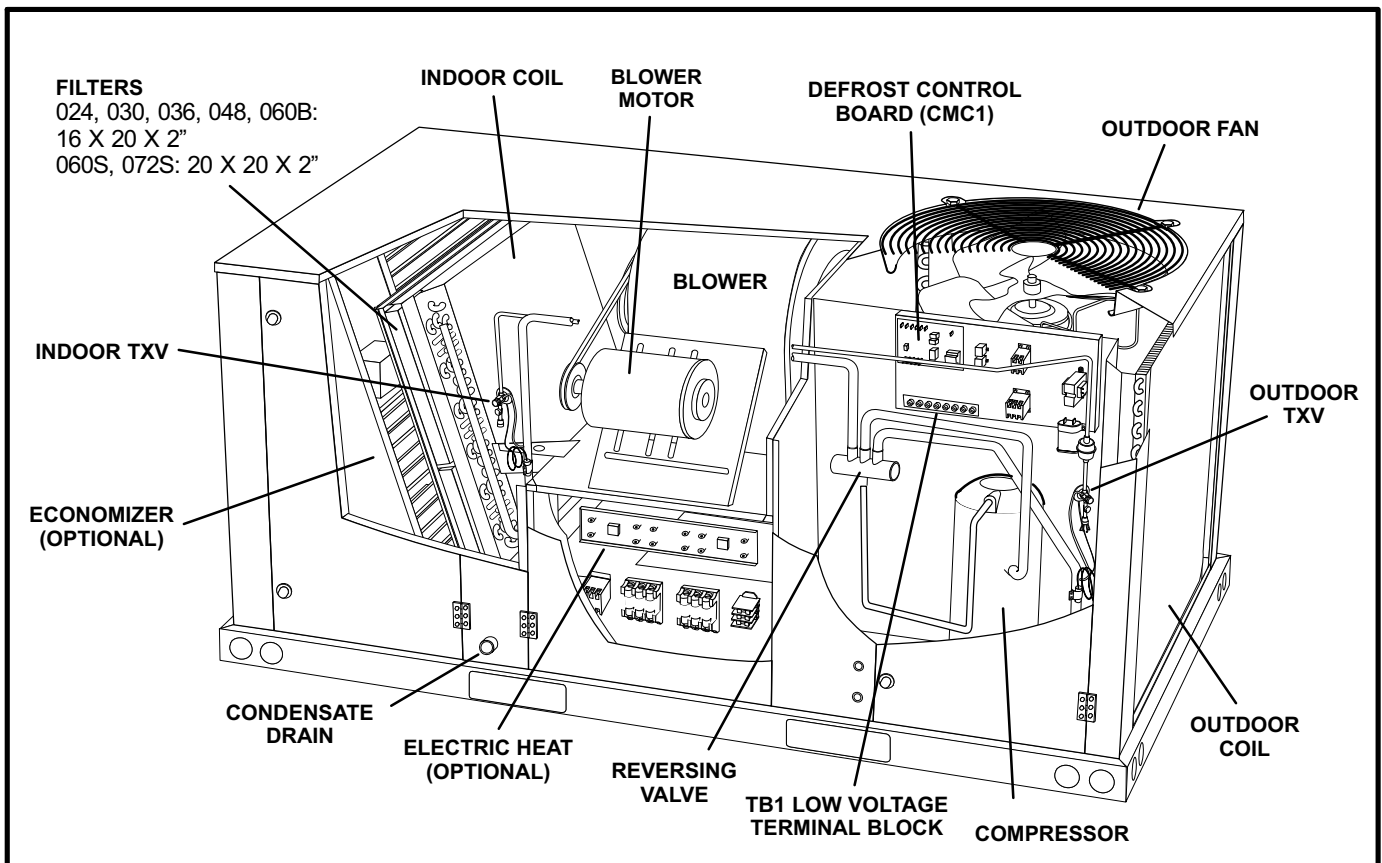

**KHA024, 030, 036, 048, 060, 072 DIMENSIONS in (mm)**

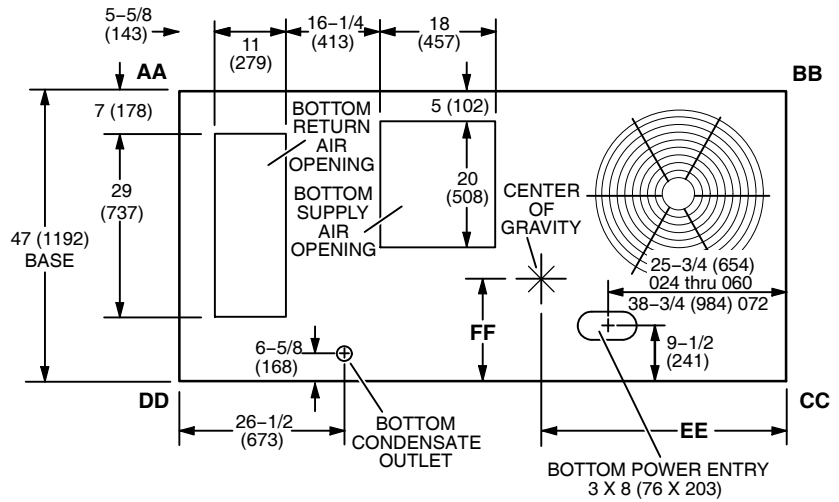

**TOP VIEW (Base)**

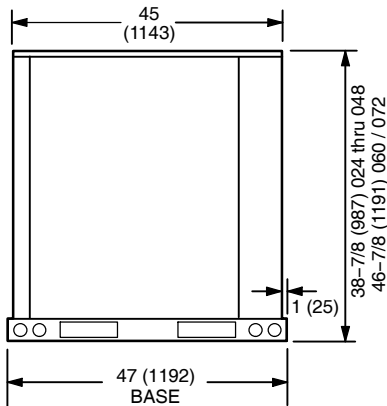

**END VIEW**

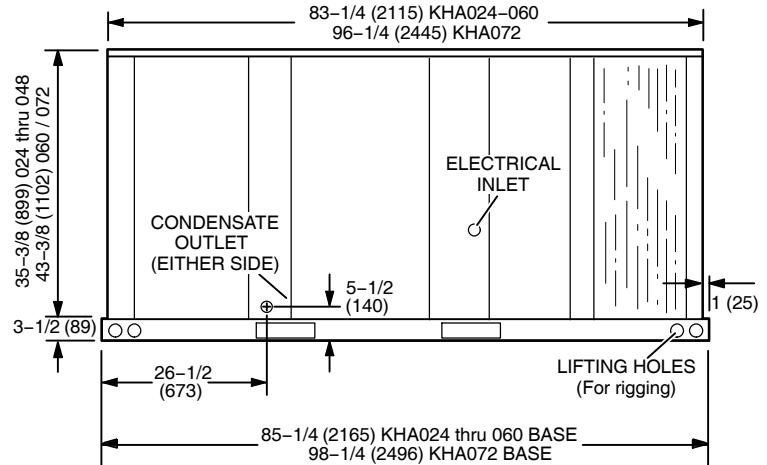

**SIDE VIEW**

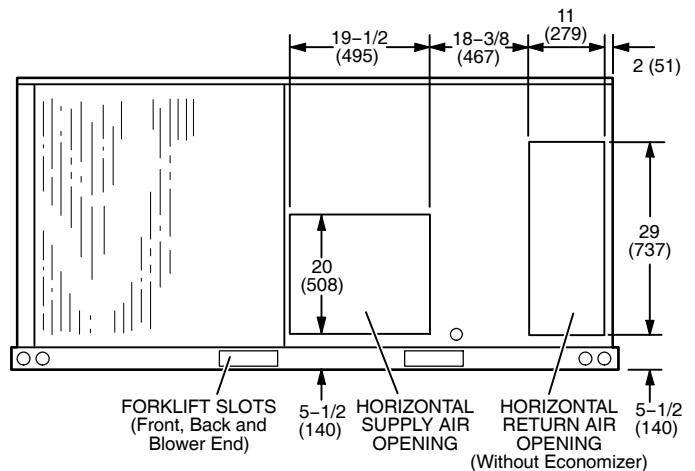

**BACK VIEW**

## Shipping and Packing List

**Package 1 of 1 contains:**

1 - Assembled unit

Check unit for shipping damage. Receiving party should contact last carrier immediately if shipping damage is found.

## General

These instructions are intended as a general guide and do not supersede local codes in any way. Authorities having jurisdiction should be consulted before installation.

Availability of units and options varies by brand.

## Requirements

The KHA unit is ETL/CSA certified as a heat pump with cooling and with or without auxiliary electric heat for non-residential use only at the clearances to combustible materials as listed on the unit nameplate and in figure 1.

Installation of KHA heat pumps must conform with standards in National Fire Protection Association (NFPA) "Standard for Installation of Air Conditioning and Ventilating Systems NFPA No. 90A," "Standard for Installation of Residence Type Warm Air Heating and Air conditioning Systems NFPA No. 90B," local municipal building codes and manufacturer's installation instructions.

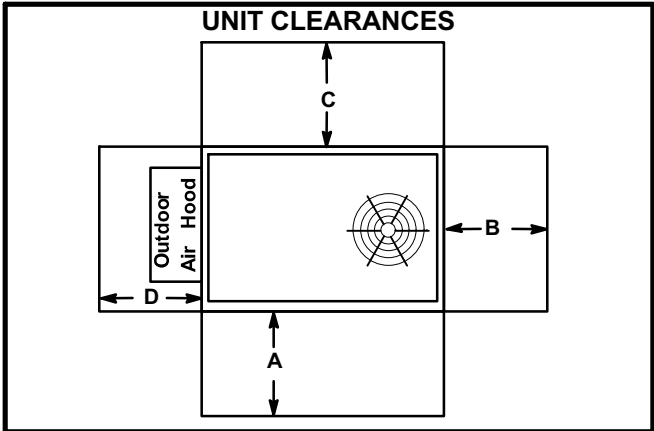

**FIGURE 1**

| <sup>1</sup> Unit Clearance      | A<br>in.<br>(mm) | B<br>in.<br>(mm) | C<br>in.<br>(mm) | D<br>in.<br>(mm) | Top Clearance     |
|----------------------------------|------------------|------------------|------------------|------------------|-------------------|
| Service Clearance                | 36<br>(914)      | 36<br>(914)      | 36<br>(914)      | 36<br>(914)      | Unob-<br>structed |
| Minimum Opera-<br>tion Clearance | 36<br>(914)      | 36<br>(914)      | 36<br>(914)      | 36<br>(914)      | Unob-<br>structed |

Note - Entire perimeter of unit base requires support when elevated above mounting surface.

<sup>1</sup> **Service Clearance** - Required for removal of serviceable parts.  
**Minimum Operation Clearance** - Required clearance for proper unit operation.

## ⚠ NOTICE

**Roof Damage!**  
**This system contains both refrigerant and oil. Some rubber roofing material may absorb oil, causing the rubber to swell. Bubbles in the rubber roofing material can cause leaks. Protect the roof surface to avoid exposure to refrigerant and oil during service and installation. Failure to follow this notice could result in damage to roof surface.**

The National Electric Code (ANSI/NFPA No. 70-1984) is available from:

National Fire Protection Association  
 1 Batterymarch Park  
 PO Box 9101  
 Quincy, MA 02269-9101

Installation of ETL/CSA certified units must also conform with current standard C273.5 "Installation Requirements for Heat Pumps" and applicable local codes. Authorities having jurisdiction should be consulted before installation.

Use of this unit as a construction heater or air conditioner is not recommended during any phase of construction. Very low return air temperatures, harmful vapors and operation of the unit with clogged or misplaced filters will damage the unit.

If this unit has been used for heating or cooling of buildings or structures under construction, the following conditions must be met or the warranty will be void:

- A room thermostat must control the unit. The use of fixed jumpers that will provide continuous heating or cooling is not allowed.
- A pre-filter must be installed at the entry to the return air duct.
- The return air duct must be provided and sealed to the unit.
- Return air temperature range between 55°F (13°C) and 80°F (27°C) must be maintained.
- Air filters must be replaced and pre-filter must be removed upon construction completion.
- The unit components, duct system, air filters and evaporator coil must be thoroughly cleaned following final construction clean-up.
- The unit operating conditions (including airflow, cooling operation, and heating operation) must be verified according to these installation instructions.

## ⚠ CAUTION

**Danger of sharp metallic edges. Can cause injury. Take care when servicing unit to avoid accidental contact with sharp edges.**

## **⚠ WARNING**



**Electric shock hazard and danger of explosion. Can cause injury, death or product or property damage. Turn off electrical power to unit before performing any maintenance or servicing operations on the unit.**

## **⚠ IMPORTANT**

**The Clean Air Act of 1990 bans the intentional venting of refrigerant (CFC's and HCFC's) as of July 1, 1992. Approved methods of recovery, recycling or reclaiming must be followed. Fines and/or incarceration may be levied for non-compliance.**

### **Unit Support**

*NOTE - Securely fasten roof frame to roof per local codes.*

KH 024, 030, 036, 048, 060 units are installed on T1CURB frames. KH 072 units are installed on K1CURB or T1CURB frames. K1CURB is a full-perimeter curb for KH 072 units; KH 072 will overhang T1CURB frame.

#### **A - Downflow Discharge Application**

##### **Roof Mounting with T1CURB or K1CURB**

- 1- The T1CURB/K1CURB roof mounting frame must be installed, flashed and sealed in accordance with the instructions provided with the frame.
- 2- The T1CURB/K1CURB roof mounting frame should be square and level to 1/16" per linear foot (5mm per linear meter) in any direction.
- 3- Duct must be attached to the roof mounting frame and not to the unit; supply and return plenums must be installed before setting the unit.

#### **Installer's Roof Mounting Frame**

Many types of roof frames can be used to install the unit, depending upon different roof structures. Items to keep in mind when using the building frame or supports are:

- 1- The unit base is fully enclosed and insulated, so an enclosed frame is not required.
- 2- The frames or supports must be constructed with non-combustible materials and should be square and level to 1/16" per linear foot (5mm per linear meter) in any direction.
- 3- Frame or supports must be high enough to prevent any form of moisture from entering unit. Recommended minimum frame height is 14" (356mm).
- 4- Duct must be attached to the roof mounting frame and not to the unit. Supply and return plenums must be installed before setting the unit.
- 5- Units require support along all four sides of unit base. Supports must be constructed of steel or suitably treated wood materials.

*NOTE-When installing unit on a combustible surface for downflow discharge applications, the T1CURB/K1CURB roof mounting frame is required.*

## B - Horizontal Discharge Applications

- 1- Units which are equipped with an optional economizer and installed in horizontal airflow applications must use a horizontal conversion kit.
- 2- Specified installation clearances must be maintained when installing units. Refer to figure 1.
- 3- Top of support slab should be at least 4" (102mm) above the finished grade and located so no run-off water from higher ground can collect around the unit.
- 4- Units require support along all four sides of unit base. Supports must be constructed of steel or suitably treated wood materials.

## Duct Connection

All exterior ducts, joints, and openings in roof or building walls must be insulated and weatherproofed with flashing and sealing compounds in accordance with applicable codes. Any duct passing through an unconditioned space must be insulated.



## CAUTION

In downflow applications, do not drill or punch holes in base of unit. Leaking in roof may occur if unit base is punctured.

## Rigging Unit For Lifting

- 1- Detach wooden base protection before rigging.
- 2- Remove all six base protection brackets before setting unit.
- 3- Connect rigging to the unit base using both holes in each corner. See figure 2.
- 4- All panels must be in place for rigging.
- 5- Place field-provided H-style pick in place just above top edge of unit. Frame must be of adequate strength and length. (H-style pick prevents damage to unit.)

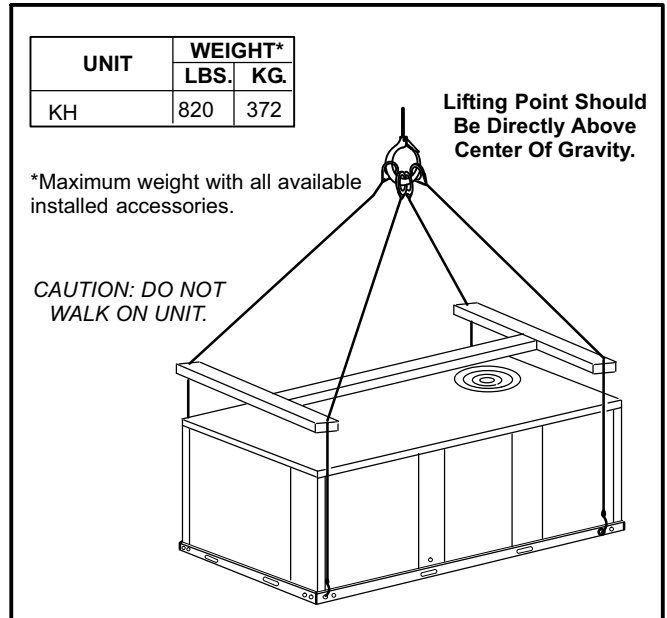

FIGURE 2

## Horizontal Air Discharge

Unit is shipped with panels covering the horizontal supply and return air openings. Remove horizontal covers and place over downflow openings for horizontal air discharge. See figure 3. Secure in place with sheet metal screws.

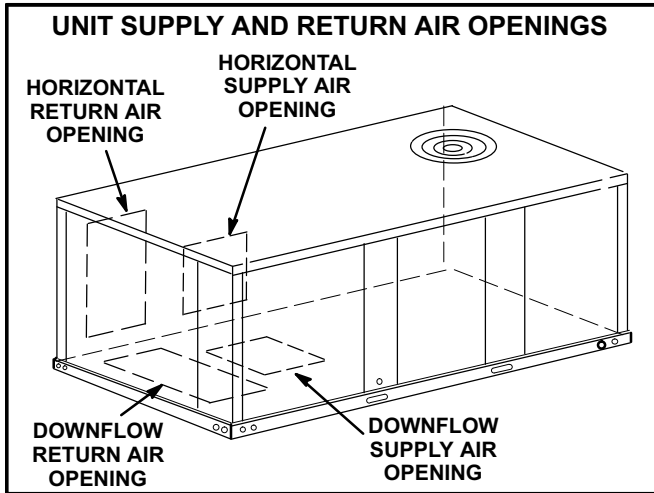

FIGURE 3

Units Equipped With An Optional Economizer -

- 1- Remove the horizontal supply air cover and position over the downflow supply air opening. Secure with sheet metal screws.
- 2- Leave the horizontal return air cover in place.
- 3- Locate the separately ordered horizontal air discharge kit. Place the kit panel over the downflow return air opening.
- 4- Remove and retain the barometric relief dampers and lower hood.
- 5- Install return air duct beneath outdoor air intake. See figure 4. Install barometric relief damper in lower hood and install in duct as shown in figure 4.

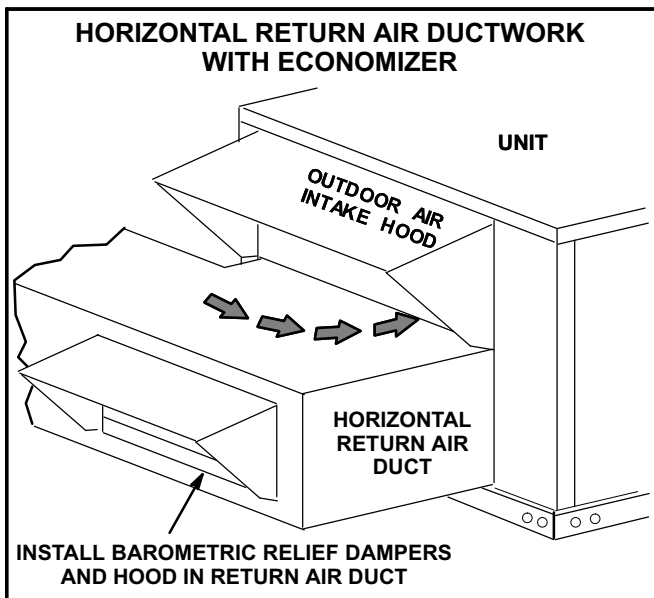

FIGURE 4

## Condensate Drains

Make drain connection to the drain coupling provided on unit. Older model units have a 3/4" N.P.T. coupling and newer model units have a 1" N.P.T. coupling.

*Note - The drain pan is made with a glass reinforced engineered plastic capable of withstanding typical joint torque but can be damaged with excessive force. Tighten pipe nipple hand tight and turn an additional quarter turn.*

A trap must be installed between drain connection and an open vent for proper condensate removal. See figure 5 or 6. It is sometimes acceptable to drain condensate onto the roof or grade; however, a tee should be fitted to the trap to direct condensate downward. The condensate line must be vented. Check local codes concerning condensate disposal. Refer to pages 1 and 2 for condensate drain location.

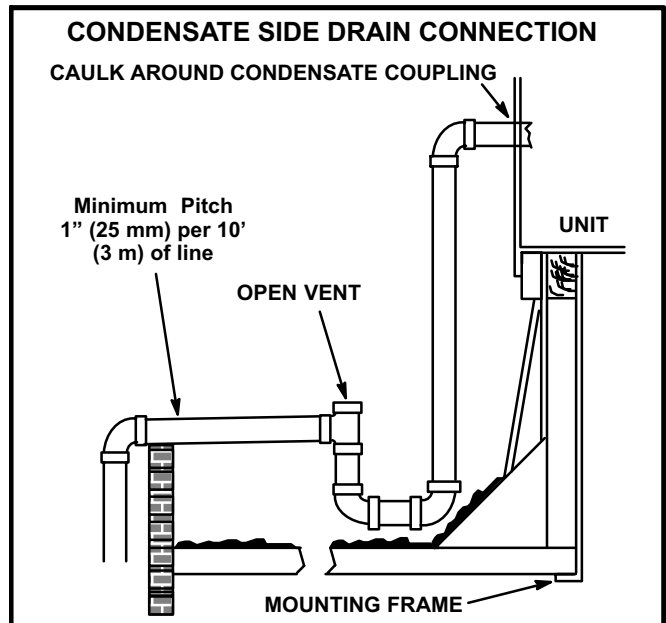

FIGURE 5

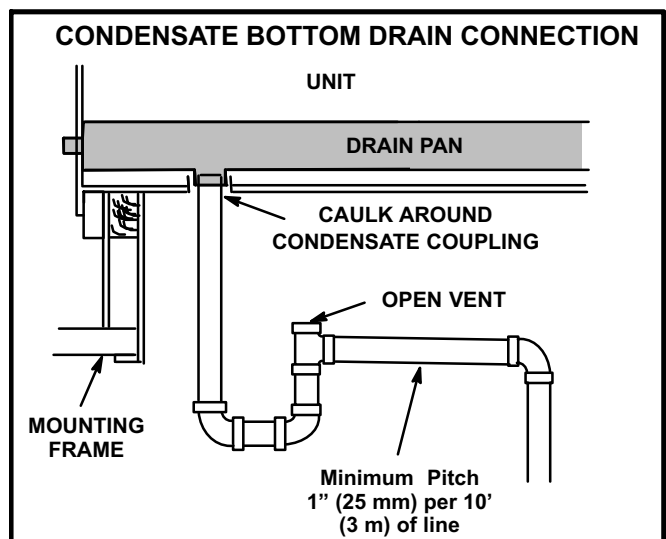

FIGURE 6

Units are shipped with the drain coupling facing the front of the unit. Condensate can be drained from the back or bottom of the unit with the following modifications. The unit can be installed in either downflow or horizontal air discharge regardless of condensate drain location.

### Rear Drain Connection

- 1- Remove the condensate drain mullion. See figure 7. Remove the two panels on each side of the mullion.

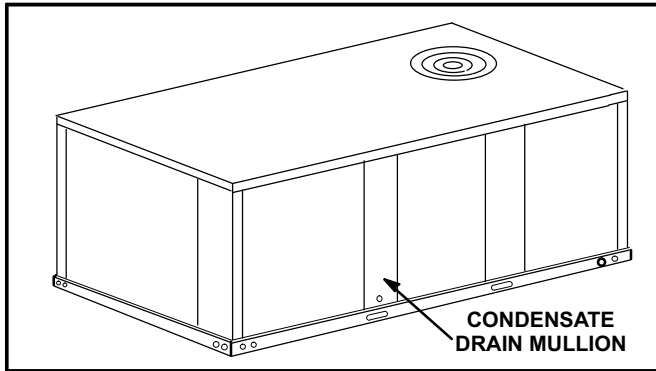

FIGURE 7

If the unit has hinged panels, two hinge screws must be removed in addition to the mullion screws. See figure 8.

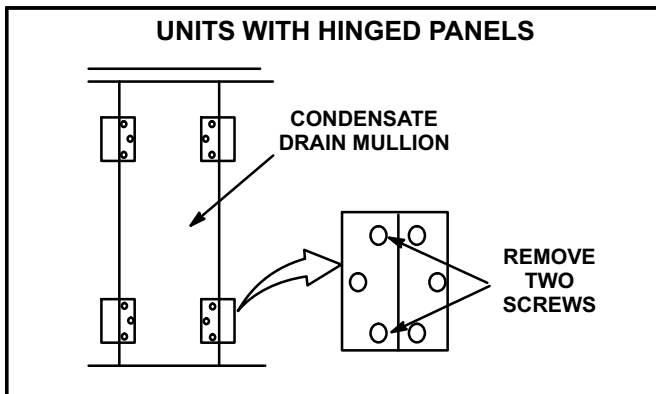

FIGURE 8

- 2- Lift the front edge of the drain pan and slide pan out of unit. See figure 9.

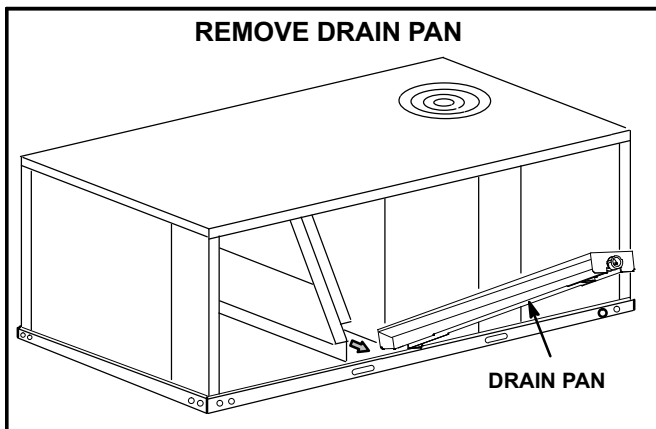

FIGURE 9

- 3- Make sure the cap over the unit bottom drain hole is secure.
- 4- Rotate the drain pan until the downward slope is toward the back of the unit. Slide the drain pan back into the unit. Be careful not to dislodge the cap over the bottom drain hole.
- 5- From the back side of the unit, pull the drain pan coupling through the rear condensate opening.
- 6- Replace the condensate drain mullion.

### Bottom Drain Connection

- 1- Remove the condensate drain mullion. See figure 7.
- 2- Lift the front edge of the drain pan and slide pan out of unit. See figure 9.
- 3- Turn the drain pan upside down and drill a pilot hole through the bottom of the drain pan in the center of the coupling. See figure 10.
- 4- From the inside of the pan, use a Vari-Bit® bit to enlarge the hole to 7/8". Do not damage coupling threads.
- 5- Remove the cap over the unit bottom drain hole.
- 6- Slide the drain pan back into the unit.
- 7- From the back side of the unit, pull the drain pan coupling through the rear condensate opening.
- 8- From the front side of the unit, move the drain pan until the bottom coupling settles into the unit bottom drain opening. Once in place, check to make sure the coupling is still positioned through the rear condensate drain hole.
- 9- Use a field-provided 3/4" plug to seal side drain connection.
- 10- Replace the condensate drain mullion.

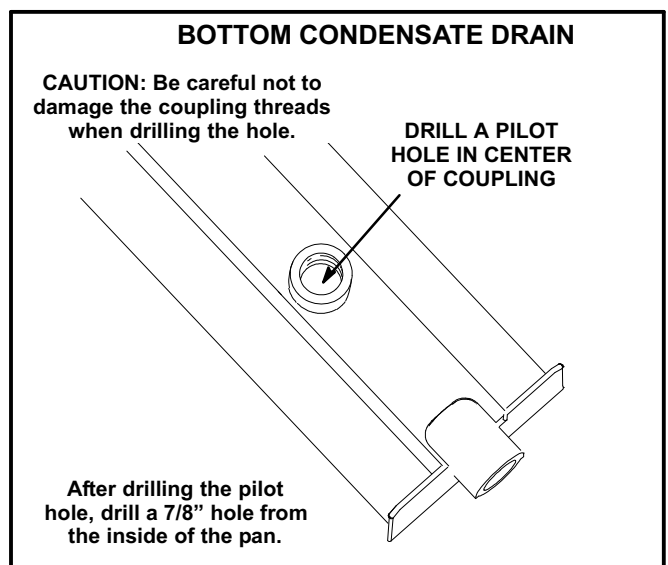

FIGURE 10

## Electrical Connections

### POWER SUPPLY

Do not apply power or close disconnect switch until installation is complete. Refer to start-up directions. Refer closely to unit wiring diagram. Figure 12 shows a typical unit wiring diagram.

Refer to unit nameplate for minimum circuit ampacity and maximum fuse size.

- 1- Units are factory-wired for 240,460,575 volt supply. **For 208V supply**, remove the insulated terminal cover from the 208V terminal on the control transformer. Move the wire from the transformer 240V terminal to the 208V terminal. Place the insulated terminal cover on the unused 240V terminal.
- 2- Route power through the bottom power entry area and connect to TB2. Secure power wiring with factory-installed wire ties provided in control box. See unit wiring diagram.

### CONTROL WIRING

#### A - Thermostat Location

Room thermostat mounts vertically on a standard 2" X 4" handy box or on any non-conductive flat surface.

Locate thermostat approximately 5 feet (1524 mm) above the floor in an area with good air circulation at average temperature. Avoid locating the room thermostat where it might be affected by:

- drafts or dead spots behind doors and in corners
- hot or cold air from ducts
- radiant heat from sun or appliances
- concealed pipes and chimneys

**IMPORTANT** - Unless field thermostat wires are rated for maximum unit voltage, they must be routed away from line voltage wiring. Use wire ties located near the lower left corner of the controls hat section to secure thermostat cable.

#### B - Control Wiring

- 1- Route thermostat cable or wires from subbase to control area above compressor (refer to unit dimensions to locate bottom and side power entry). Use 18 AWG wire for all applications using remotely installed electro-mechanical and electronic thermostats.
- 2- Install thermostat assembly in accordance with instructions provided with thermostat.
- 3- Connect thermostat wiring to TB1 terminal control board on the lower side of the controls hat section. Wire as shown in figure 11 for electro-mechanical and electronic thermostats. If using other temperature control devices or energy management systems see instructions and wiring diagram provided by manufacturer.

**IMPORTANT**-Terminal connections at the wall plate or subbase must be made securely. Loose control wire connections may allow unit to operate but not with proper response to room demand.

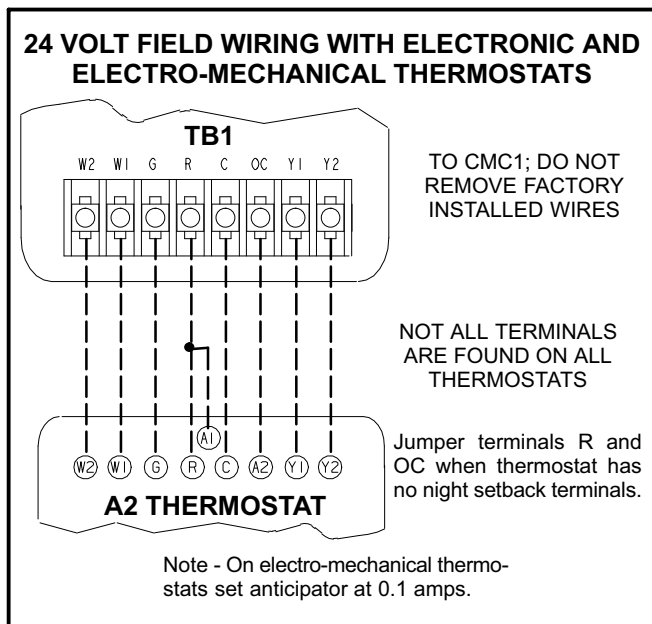

FIGURE 11



# TYPICAL KHA UNIT WIRING SCHEMATIC

24V POWER

NOTE-FOR USE WITH COPPER CONDUCTORS ONLY  
REFER TO UNIT RATING PLATE FOR MINIMUM CIRCUIT  
AMPACITY AND MAXIMUM OVERCURRENT PROTECTION SIZE  
S40 IS NOT REQ'D ON 072 UNITS

ECONOMIZER

BLOWER(G)

HEAT 1(W1)

HEAT 2(W2)

COOL 1(Y1)

24V COMMON

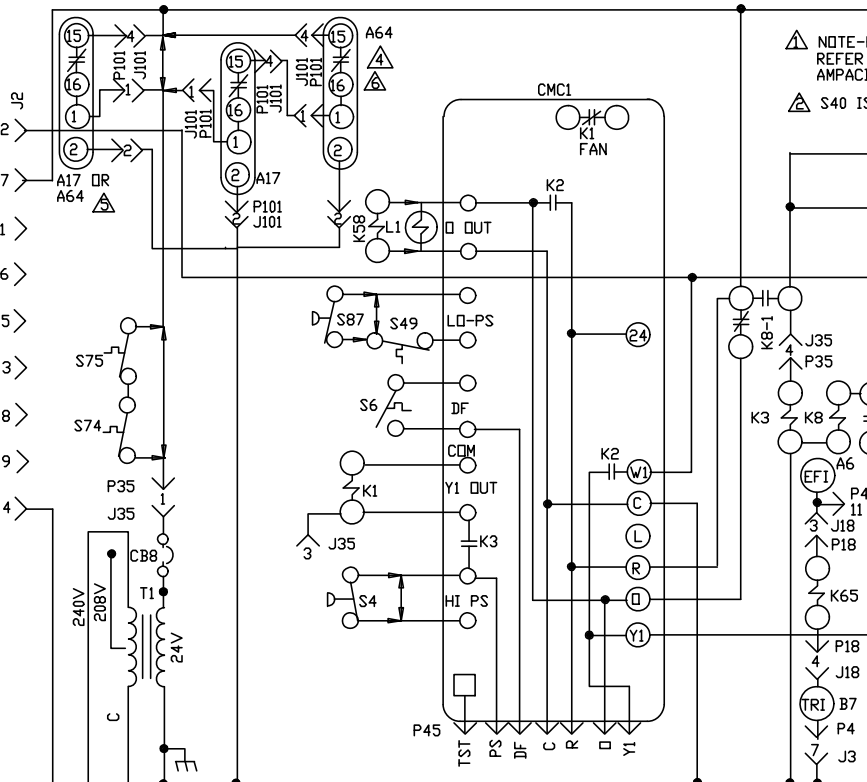

| KEY | DESCRIPTION                  | COMPONENT |
|-----|------------------------------|-----------|
| A6  | CONTROL-SOLID STATE ENTHALPY |           |
| A17 | DETECTOR-SMOKE, RETURN AIR   |           |
| A64 | DETECTOR-SMOKE, SUPPLY AIR   |           |
| B1  | COMPRESSOR                   |           |
| B3  | MOTOR-BLOWER                 |           |
| B4  | MOTOR-OUTDOOR FAN            |           |
| B7  | MOTOR-DAMPER ECONOMIZER      |           |
| B10 | MOTOR-EXHAUST FAN            |           |
| C1  | CAPACITOR-OUTDOOR FAN        |           |
| C4  | CAPACITOR-BLOWER MOTOR       |           |
| C6  | CAPACITOR-EXHAUST FAN        |           |

IMPORTANT: TO PREVENT MOTOR BURNOUT, NEVER  
CONNECT MORE THAN ONE MOTOR LEAD TO ANY  
ONE CONNECTION. TAPE UNUSED MOTOR LEADS

CONNECTIONS FOR REMOTE MOUNTED SMOKE DETECTORS  
A17 & A64, MAX LOAD 0.1VA 24VAC CLASS II EACH

A17 ONLY OR A64 ONLY HOOKUP

A17 AND A64 HOOKUP

|          |   |
|----------|---|
| C88      | CIRCUIT BREAKER-TRANSFORMER T1                  |
| CMC1     | TIMER-DEFROST, COMPRESSOR 1                     |
| F6       | FUSE-EXHAUST FAN                                |
| HRI      | HEATER COMPRESSOR                               |
| J2       | JACK-HEAT                                       |
| J3       | JACK-UNIT ECONOMIZER                            |
| J18      | JACK-EXHAUST FAN                                |
| J35      | JACK-TEST                                       |
| J132     | JACK-BLOWER, EXHAUST FAN MOTOR                  |
| K1,-1    | CONTACTOR-COMPRESSOR                            |
| K3,-1    | CONTACTOR-BLOWER                                |
| K8,-1,2  | RELAY-TRANSFER 1                                |
| K58,-1   | RELAY-LOW AMBIENT KIT                           |
| K65,-1,2 | RELAY-EXHAUST FAN                               |
| L1       | VALVE-REVERSING                                 |
| P4       | PLUG-ECONOMIZER                                 |
| P18      | PLUG-EXHAUST FAN                                |
| P35      | PLUG-TEST                                       |
| P43      | PLUG-BLOWER MOTOR                               |
| P45      | PLUG-INPUT                                      |
| P132     | PLUG-BLOWER, EXHAUST FAN MOTOR                  |
| S3       | SWITCH-LIMIT, LOW COMP 1<br>/COMPRESSOR MONITOR |
| S4       | SWITCH-LIMIT, HI PRESS (MANUAL RESET)           |
| S6       | SWITCH-DEFROST, COMPRESSOR 1                    |
| S11      | SWITCH-LOW PRESS, LOW AMB KIT                   |
| S40      | THERMOSTAT-CRANKCASE                            |
| S49      | SWITCH-FREEZESTAT                               |
| S74      | SWITCH-FIRESTAT 1                               |
| S75      | SWITCH-FIRESTAT 2                               |
| S87      | SWITCH-LOW PRESS, COMPRESSOR 1                  |
| T1       | TRANSFORMER-CONTROL                             |

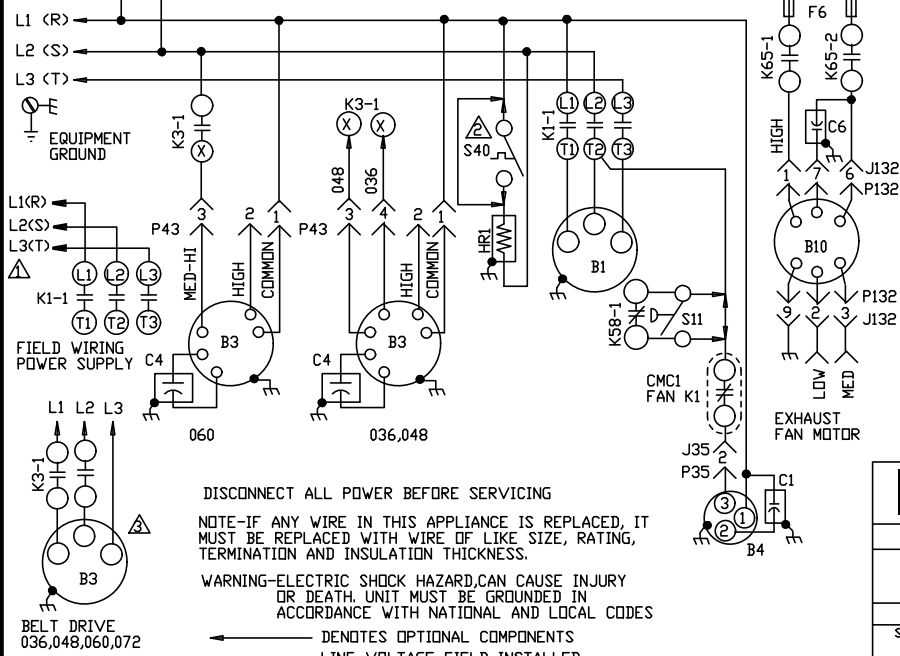

DISCONNECT ALL POWER BEFORE SERVICING

NOTE-IF ANY WIRE IN THIS APPLIANCE IS REPLACED, IT  
MUST BE REPLACED WITH WIRE OF LIKE SIZE, RATING,  
TERMINATION AND INSULATION THICKNESS.

WARNING-ELECTRIC SHOCK HAZARD, CAN CAUSE INJURY  
OR DEATH. UNIT MUST BE GROUNDED IN  
ACCORDANCE WITH NATIONAL AND LOCAL CODES

← DENOTES OPTIONAL COMPONENTS

— LINE VOLTAGE FIELD INSTALLED

WIRING DIAGRAM 11/07

**COOLING UNITS-PACKAGED**

KHA, THA-036,048,060,072-Y

208-230/60/3

**COOLING SECTION B33**

|                     |              |
|---------------------|--------------|
| Supersedes Form No. | New Form No. |
| 535,026W            | 535,026W     |

© 2007 Litho U.S.A.

FIGURE 12

## Blower Operation and Adjustments

Units are equipped with direct or belt drive blowers; available drive varies by model.

### ⚠️ IMPORTANT

Three phase scroll compressors must be phased sequentially for correct compressor and blower rotation. Follow "COOLING START-UP" section of installation instructions to ensure proper compressor and blower operation.

#### A - Blower Operation

- 1- Set thermostat or temperature control device fan switch to **AUTO** or **ON**. With fan switch in **ON** position, blower will operate continuously. With fan switch in **AUTO** position, the blower will cycle with demand.
- 2- Blower and entire unit will be off when thermostat or temperature control device system switch is in **OFF** position.

#### B - Determining Unit CFM - Direct Drive Blowers

- 1- The following measurements must be made with air filters in place.
- 2- With all access panels in place, measure static pressure external to unit (from supply to return). Add any additional air resistance for options and accessories shown in 8.
- 3- Use figure 13 to determine the factory set blower speed.

#### BLOWER SPEED FACTORY SETTINGS

| 036 Units                              | 024, 030,<br>048 Units                 | 060 Units                              |
|--|--|--|
| <input type="checkbox"/> 1 Com         | <input type="checkbox"/> 1 Com         | <input type="checkbox"/> 1 Com         |
| <input type="checkbox"/> 2 Hi          | <input type="checkbox"/> 2 Hi          | <input type="checkbox"/> 2 Hi          |
| <input type="checkbox"/> 3 Med         | <input type="checkbox"/> 3 <b>Med*</b> | <input type="checkbox"/> 3 <b>Low*</b> |
| <input type="checkbox"/> 4 <b>Low*</b> | <input type="checkbox"/> 4 Low         | <input type="checkbox"/> 4 Unused      |

\*Factory Setting

FIGURE 13

- 4- Use tables 2 through 7, the measured static pressure, and the factory-set blower speed to determine CFM. If CFM is lower than the design specified CFM, move the lead from speed tap 3 or 4 to speed tap 2. See figure 14. Refer to table 9 for minimum airflow when electric heat is installed.

For 460/575V units, remove the isolation lead from speed tap 2 before moving the wire to speed tap 2. Tape the exposed end of the isolation lead and secure away from other components.

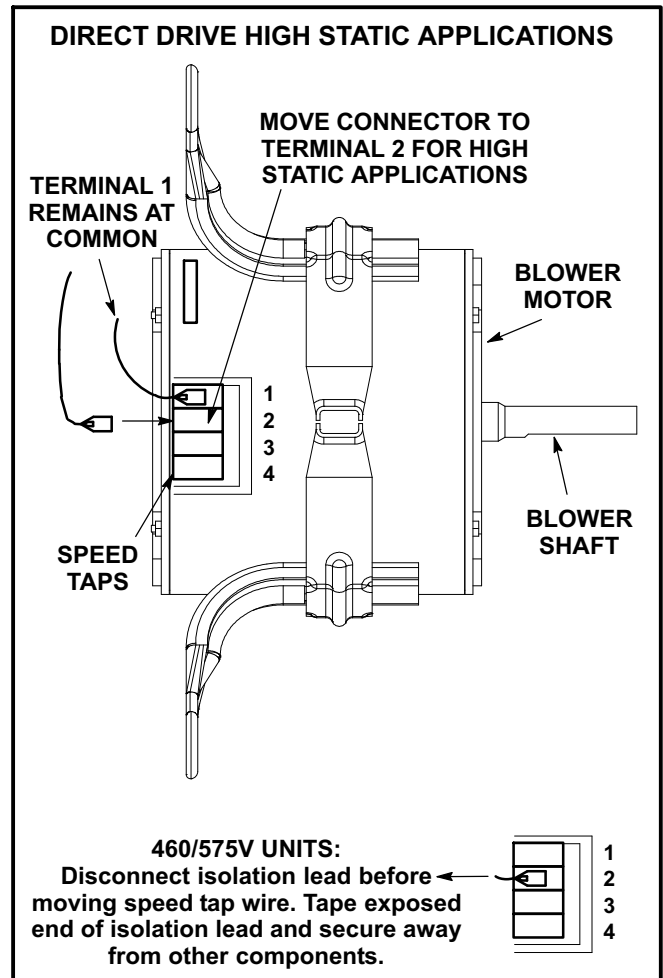

FIGURE 14

### C - Determining Unit CFM - Belt Drive Blowers

- 1- The following measurements must be made with air filters in place.
- 2- With all access panels in place, measure static pressure external to unit (from supply to return).
- 3- Measure the indoor blower wheel RPM.
- 4- Referring to tables 3 through 7, use static pressure and RPM readings to determine unit CFM. Use table 8 when installing units with any of the options or accessories listed. Refer to table 9 for minimum airflow when electric heat is installed.
- 5- The blower RPM can be adjusted at the motor pulley. Loosen Allen screw and turn adjustable pulley clockwise to increase CFM. Turn counterclockwise to decrease CFM. See figure 16. Do not exceed minimum and maximum number of pulley turns as shown in table 1.

**TABLE 1  
MINIMUM AND MAXIMUM PULLEY ADJUSTMENT**

| Belt      | Min. Turns Open | Maxi. Turns Open |
|-----------|-----------------|------------------|
| A Section | No minimum      | 5                |

### D - Blower Belt Adjustment

Maximum life and wear can be obtained from belts only if proper pulley alignment and belt tension are maintained. Tension new belts after a 24-48 hour period of operation. This will allow belt to stretch and seat grooves. Make sure blower and motor pulley are aligned as shown in figure 15.

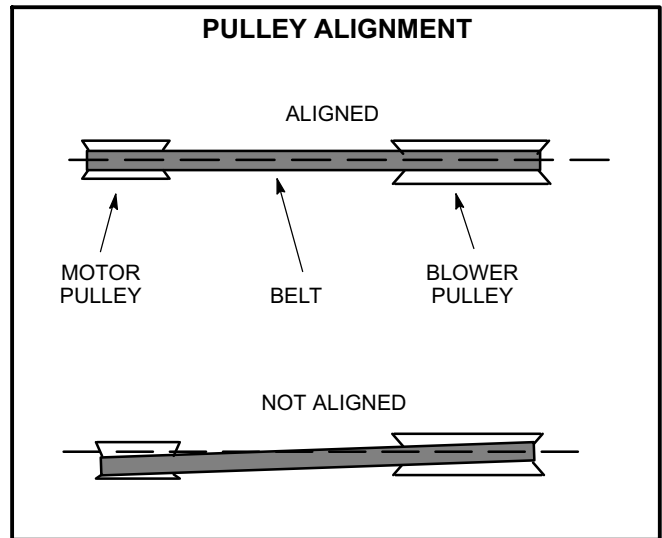

**FIGURE 15**

- 1- Loosen four bolts securing motor base to mounting frame. See figure 16.
- 2- *To increase belt tension -*  
Slide blower motor downward to tighten the belt. This increases the distance between the blower motor and the blower housing.
- To loosen belt tension -*  
Slide blower motor upward to loosen the belt. This decreases the distance between the blower motor and the blower housing.
- 3- Tighten four bolts securing motor base to the mounting frame.

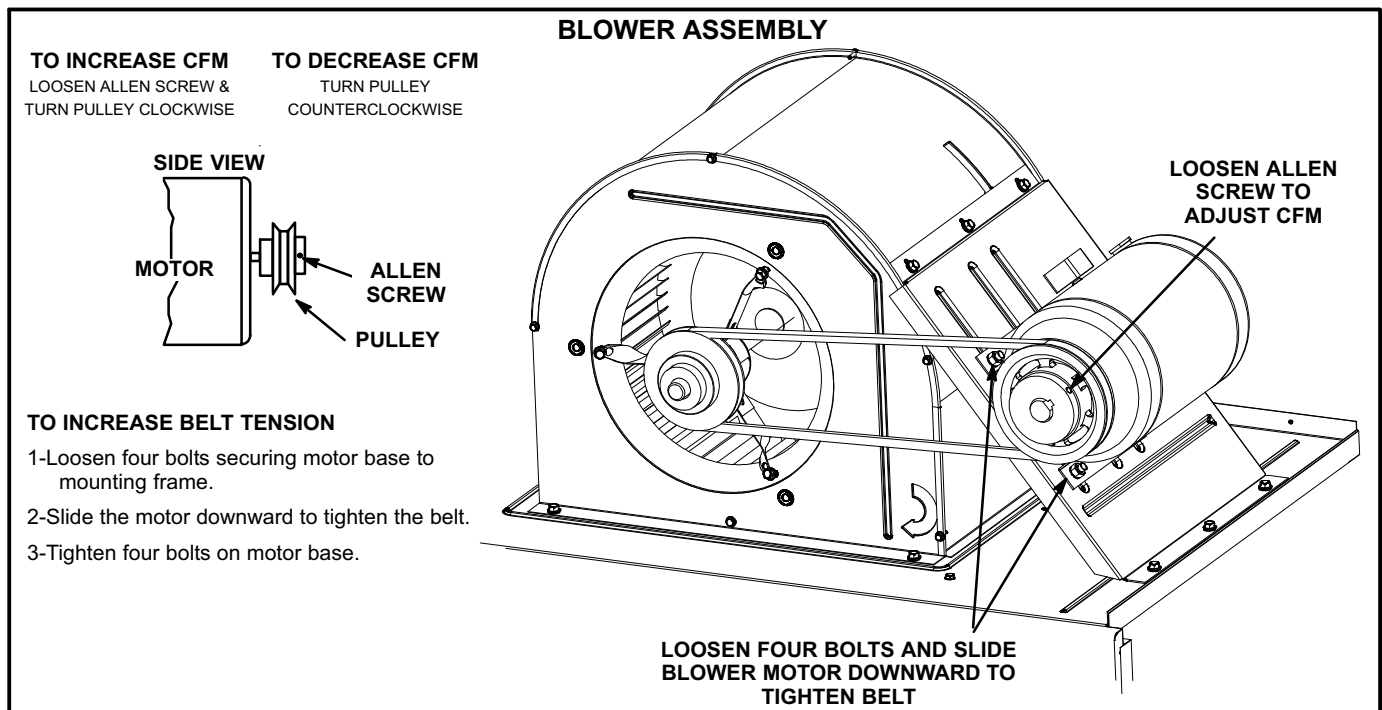

**FIGURE 16**

**E - Check Belt Tension**

Overtensioning belts shortens belt and bearing life. Check belt tension as follows:

- 1- Measure span length X. See figure 17.
- 2- Apply perpendicular force to center of span (X) with enough pressure to deflect belt 1/64" for every inch of span length or 1.5mm per 100mm of span length.

Example: Deflection distance of a 40" span would be 40/64" or 5/8".

Example: Deflection distance of a 400mm span would be 6mm.

- 3- Measure belt deflection force. For a used belt, the deflection force should be 5 lbs. (35kPa). A new belt deflection force should be 7 lbs. (48kPa).

A force below these values indicates an undertensioned belt. A force above these values indicates an overtensioned belt.

**F-Field-Furnished Blower Drives**

For field-furnished blower drives, use tables 3 through 7 to determine BHP and RPM required. Reference table 10 to determine the drive kit number and figure 11 for drive kit specifications..

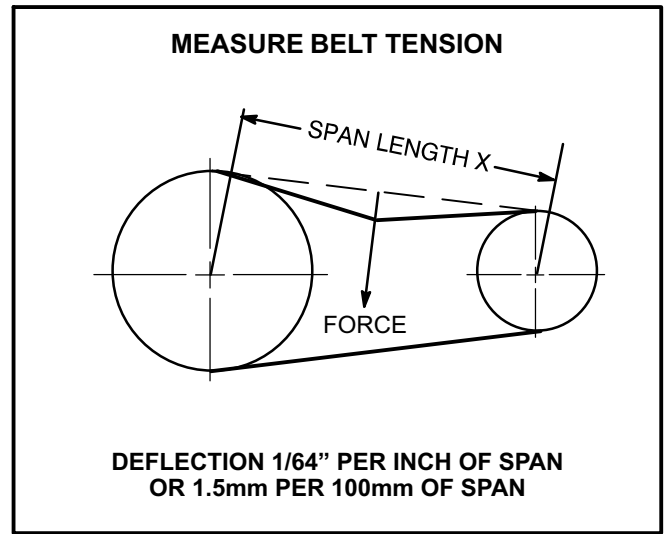

**FIGURE 17**

**TABLE 2  
DIRECT DRIVE BLOWER PERFORMANCE**

| External Static Pressure (in. w.g.)                   | Air Volume (cfm) at Various Blower Speeds |        |     |                            |        |     |
|---|---|--------|-----|----------------------------|--------|-----|
|   | 208 VOLTS                                 |        |     | 230 VOLTS                  |        |     |
|   | High                                      | Medium | Low | High                       | Medium | Low |
| <b>2 and 2.5 Ton Standard Efficiency (Down-Flow)</b>  |   |        |     | <b>KHA024S and KHA030S</b> |        |     |
| 0.0   | 1230                                      | 975    | 845 | 1425                       | 1125   | 910 |
| 0.1   | 1220                                      | 940    | 815 | 1395                       | 1110   | 875 |
| 0.2   | 1205                                      | 910    | 775 | 1375                       | 1085   | 845 |
| 0.3   | 1185                                      | 880    | 730 | 1350                       | 1055   | 815 |
| 0.4   | 1155                                      | 845    | 680 | 1320                       | 1010   | 780 |
| 0.5   | 1115                                      | 800    | --- | 1280                       | 955    | 740 |
| 0.6   | 1060                                      | 750    | --- | 1225                       | 895    | 690 |
| 0.7   | 985                                       | 685    | --- | 1150                       | 830    | --- |
| 0.8   | 890                                       | ---    | --- | 1050                       | 755    | --- |
| 0.9   | 770                                       | ---    | --- | 920                        | 680    | --- |
| 1.0   | ---                                       | ---    | --- | 760                        | ---    | --- |
| <b>2 and 2.5 Ton Standard Efficiency (Horizontal)</b> |   |        |     | <b>KHA024S and KHA030S</b> |        |     |
| 0.0   | 1165                                      | 925    | 800 | 1350                       | 1065   | 865 |
| 0.1   | 1155                                      | 895    | 770 | 1325                       | 1055   | 830 |
| 0.2   | 1140                                      | 865    | 735 | 1300                       | 1030   | 800 |
| 0.3   | 1125                                      | 835    | 695 | 1280                       | 1000   | 770 |
| 0.4   | 1095                                      | 800    | 645 | 1250                       | 955    | 740 |
| 0.5   | 1055                                      | 760    | --- | 1215                       | 905    | 700 |
| 0.6   | 1005                                      | 710    | --- | 1160                       | 850    | 655 |
| 0.7   | 935                                       | 650    | --- | 1090                       | 785    | --- |
| 0.8   | 845                                       | ---    | --- | 995                        | 720    | --- |
| 0.9   | 730                                       | ---    | --- | 875                        | 645    | --- |
| 1.0   | ---                                       | ---    | --- | 720                        | ---    | --- |

**TABLE 3  
BELT DRIVE BLOWER PERFORMANCE**

0.10 to 1.00 in. w.g.

3 Ton Standard Efficiency (Down-Flow)

KHA036S

| Air Volume (cfm) | External Static (in.w.g.) |      |      |      |                                  |      |      |      |      |      |      |      |              |      |      |      |
|------------------|---------------------------|------|------|------|----------------------------------|------|------|------|------|------|------|------|--------------|------|------|------|
|                  | 0.10                      |      | 0.20 |      | 0.30                             |      | 0.40 |      | 0.50 |      | 0.60 |      | 0.70         |      | 0.80 |      |
|                  | RPM                       | BHP  | RPM  | BHP  | RPM                              | BHP  | RPM  | BHP  | RPM  | BHP  | RPM  | BHP  | RPM          | BHP  | RPM  | BHP  |
|                  | <b>Field Furnished</b>    |      |      |      | <b>Low Static - Drive Kit #1</b> |      |      |      |      |      |      |      | <b>Kit 5</b> |      |      |      |
| 900              | 485                       | 0.10 | 595  | 0.15 | 690                              | 0.20 | 780  | 0.30 | 860  | 0.40 | 930  | 0.50 | 1000         | 0.60 | 1065 | 0.75 |
| 1000             | 520                       | 0.10 | 615  | 0.20 | 705                              | 0.25 | 790  | 0.35 | 870  | 0.45 | 945  | 0.55 | 1010         | 0.65 | 1075 | 0.75 |
| 1100             | 550                       | 0.15 | 640  | 0.20 | 725                              | 0.30 | 805  | 0.35 | 885  | 0.45 | 955  | 0.55 | 1020         | 0.70 | 1085 | 0.80 |
| 1200             | 585                       | 0.20 | 665  | 0.25 | 745                              | 0.30 | 825  | 0.40 | 900  | 0.50 | 965  | 0.60 | 1030         | 0.70 | 1095 | 0.85 |
| 1300             | 620                       | 0.20 | 695  | 0.30 | 770                              | 0.35 | 845  | 0.45 | 915  | 0.55 | 980  | 0.65 | 1045         | 0.75 | 1105 | 0.90 |
| 1400             | 660                       | 0.25 | 730  | 0.35 | 795                              | 0.40 | 865  | 0.50 | 935  | 0.60 | 995  | 0.70 | 1060         | 0.80 | 1120 | 0.95 |
| 1500             | 695                       | 0.30 | 760  | 0.40 | 825                              | 0.45 | 890  | 0.55 | 955  | 0.65 | 1015 | 0.75 | 1075         | 0.85 | 1135 | 1.00 |

0.90 to 1.60 in. w.g.

3 Ton Standard Efficiency (Down-Flow)

KHA036S

| Air Volume (cfm) | External Static (in.w.g.)         |      |      |      |      |      |                        |      |      |      |      |      |      |      |      |      |
|------------------|-----------------------------------|------|------|------|------|------|------------------------|------|------|------|------|------|------|------|------|------|
|                  | 0.90                              |      | 1.0  |      | 1.10 |      | 1.20                   |      | 1.30 |      | 1.40 |      | 1.50 |      | 1.60 |      |
|                  | RPM                               | BHP  | RPM  | BHP  | RPM  | BHP  | RPM                    | BHP  | RPM  | BHP  | RPM  | BHP  | RPM  | BHP  | RPM  | BHP  |
|                  | <b>High Static - Drive Kit #5</b> |      |      |      |      |      | <b>Field Furnished</b> |      |      |      |      |      |      |      |      |      |
| 900              | 1125                              | 0.85 | 1180 | 1.00 | 1230 | 1.10 | 1285                   | 1.25 | 1330 | 1.35 | 1380 | 1.50 | 1425 | 1.65 | 1465 | 1.80 |
| 1000             | 1130                              | 0.90 | 1190 | 1.00 | 1240 | 1.15 | 1295                   | 1.30 | 1340 | 1.40 | 1390 | 1.60 | 1435 | 1.75 | 1475 | 1.85 |
| 1100             | 1140                              | 0.90 | 1200 | 1.05 | 1250 | 1.20 | 1300                   | 1.35 | 1350 | 1.50 | 1400 | 1.65 | 1445 | 1.80 | 1485 | 1.95 |
| 1200             | 1150                              | 0.95 | 1210 | 1.10 | 1260 | 1.25 | 1310                   | 1.40 | 1360 | 1.55 | 1410 | 1.70 | 1455 | 1.85 | 1495 | 2.00 |
| 1300             | 1165                              | 1.00 | 1220 | 1.15 | 1270 | 1.30 | 1320                   | 1.45 | 1370 | 1.60 | 1415 | 1.75 | 1465 | 1.90 | 1505 | 2.05 |
| 1400             | 1175                              | 1.05 | 1230 | 1.20 | 1280 | 1.35 | 1330                   | 1.50 | 1380 | 1.65 | 1425 | 1.80 | 1470 | 1.95 | 1515 | 2.15 |
| 1500             | 1190                              | 1.15 | 1240 | 1.25 | 1295 | 1.40 | 1345                   | 1.55 | 1390 | 1.70 | 1435 | 1.90 | 1480 | 2.05 | 1525 | 2.20 |

0.10 to 0.80 in. w.g.

3 Ton Standard Efficiency (Horizontal)

KHA036S

| Air Volume (cfm) | External Static (in.w.g.) |      |      |      |                                  |      |      |      |      |      |      |      |      |      |      |      |
|------------------|---------------------------|------|------|------|----------------------------------|------|------|------|------|------|------|------|------|------|------|------|
|                  | 0.10                      |      | 0.20 |      | 0.30                             |      | 0.40 |      | 0.50 |      | 0.60 |      | 0.70 |      | 0.80 |      |
|                  | RPM                       | BHP  | RPM  | BHP  | RPM                              | BHP  | RPM  | BHP  | RPM  | BHP  | RPM  | BHP  | RPM  | BHP  | RPM  | BHP  |
|                  | <b>Field Furnished</b>    |      |      |      | <b>Low Static - Drive Kit #1</b> |      |      |      |      |      |      |      |      |      |      |      |
| 900              | 480                       | 0.10 | 570  | 0.15 | 655                              | 0.20 | 735  | 0.30 | 810  | 0.35 | 875  | 0.45 | 940  | 0.55 | 1000 | 0.65 |
| 1000             | 520                       | 0.15 | 595  | 0.15 | 675                              | 0.25 | 750  | 0.30 | 820  | 0.40 | 890  | 0.50 | 950  | 0.60 | 1010 | 0.70 |
| 1100             | 555                       | 0.15 | 625  | 0.20 | 695                              | 0.25 | 765  | 0.35 | 835  | 0.45 | 900  | 0.50 | 960  | 0.60 | 1020 | 0.75 |
| 1200             | 595                       | 0.20 | 660  | 0.25 | 725                              | 0.30 | 790  | 0.40 | 850  | 0.45 | 915  | 0.55 | 975  | 0.65 | 1030 | 0.75 |
| 1300             | 635                       | 0.25 | 690  | 0.30 | 750                              | 0.35 | 810  | 0.40 | 870  | 0.50 | 930  | 0.60 | 990  | 0.70 | 1045 | 0.80 |
| 1400             | 675                       | 0.30 | 730  | 0.35 | 785                              | 0.40 | 840  | 0.50 | 895  | 0.55 | 950  | 0.65 | 1005 | 0.75 | 1060 | 0.85 |
| 1500             | 720                       | 0.35 | 765  | 0.40 | 815                              | 0.45 | 870  | 0.55 | 920  | 0.60 | 970  | 0.70 | 1025 | 0.80 | 1075 | 0.95 |

0.90 to 1.60 in. w.g.

3 Ton Standard Efficiency (Horizontal)

KHA036S

| Air Volume (cfm) | External Static (in.w.g.)         |      |      |      |      |      |      |      |      |      |              |      |      |      |      |      |
|------------------|-----------------------------------|------|------|------|------|------|------|------|------|------|--------------|------|------|------|------|------|
|                  | 0.90                              |      | 1.0  |      | 1.10 |      | 1.20 |      | 1.30 |      | 1.40         |      | 1.50 |      | 1.60 |      |
|                  | RPM                               | BHP  | RPM  | BHP  | RPM  | BHP  | RPM  | BHP  | RPM  | BHP  | RPM          | BHP  | RPM  | BHP  | RPM  | BHP  |
|                  | <b>High Static - Drive Kit #5</b> |      |      |      |      |      |      |      |      |      | <b>Field</b> |      |      |      |      |      |
| 900              | 1055                              | 0.75 | 1105 | 0.90 | 1155 | 1.00 | 1200 | 1.10 | 1245 | 1.25 | 1285         | 1.35 | 1325 | 1.50 | 1365 | 1.60 |
| 1000             | 1065                              | 0.80 | 1115 | 0.90 | 1165 | 1.05 | 1210 | 1.15 | 1255 | 1.30 | 1300         | 1.40 | 1340 | 1.55 | 1380 | 1.70 |
| 1100             | 1075                              | 0.85 | 1125 | 0.95 | 1175 | 1.10 | 1220 | 1.20 | 1265 | 1.35 | 1310         | 1.50 | 1350 | 1.60 | 1395 | 1.75 |
| 1200             | 1085                              | 0.90 | 1135 | 1.00 | 1185 | 1.15 | 1235 | 1.25 | 1280 | 1.40 | 1320         | 1.55 | 1365 | 1.70 | 1405 | 1.85 |
| 1300             | 1095                              | 0.95 | 1145 | 1.05 | 1195 | 1.20 | 1245 | 1.30 | 1290 | 1.45 | 1330         | 1.60 | 1375 | 1.75 | 1415 | 1.90 |
| 1400             | 1110                              | 1.00 | 1160 | 1.10 | 1210 | 1.25 | 1255 | 1.40 | 1300 | 1.50 | 1340         | 1.65 | 1385 | 1.80 | 1425 | 1.95 |
| 1500             | 1125                              | 1.05 | 1175 | 1.15 | 1220 | 1.30 | 1265 | 1.45 | 1310 | 1.60 | 1355         | 1.75 | 1395 | 1.85 | 1435 | 2.05 |

**TABLE 4  
BELT DRIVE BLOWER PERFORMANCE**

0.10 to 0.80 in. w.g.

4 Ton Standard Efficiency (Down-Flow)

KHA048S

| Air Volume (cfm) | External Static (in.w.g.) |      |      |      |      |      |                                  |      |      |      |      |      |      |      |      |      |
|------------------|---------------------------|------|------|------|------|------|----------------------------------|------|------|------|------|------|------|------|------|------|
|                  | 0.10                      |      | 0.20 |      | 0.30 |      | 0.40                             |      | 0.50 |      | 0.60 |      | 0.70 |      | 0.80 |      |
|                  | RPM                       | BHP  | RPM  | BHP  | RPM  | BHP  | RPM                              | BHP  | RPM  | BHP  | RPM  | BHP  | RPM  | BHP  | RPM  | BHP  |
|                  | <b>Field Furnished</b>    |      |      |      |      |      | <b>Low Static - Drive Kit #2</b> |      |      |      |      |      |      |      |      |      |
| 1200             | 580                       | 0.15 | 665  | 0.20 | 740  | 0.30 | 820                              | 0.35 | 890  | 0.45 | 955  | 0.53 | 1020 | 0.63 | 1080 | 0.73 |
| 1300             | 620                       | 0.20 | 690  | 0.25 | 765  | 0.30 | 835                              | 0.40 | 905  | 0.48 | 970  | 0.58 | 1035 | 0.68 | 1090 | 0.78 |
| 1400             | 655                       | 0.25 | 725  | 0.30 | 795  | 0.35 | 860                              | 0.45 | 925  | 0.53 | 990  | 0.63 | 1050 | 0.73 | 1105 | 0.83 |
| 1500             | 690                       | 0.28 | 755  | 0.35 | 820  | 0.40 | 884                              | 0.50 | 945  | 0.58 | 1005 | 0.68 | 1065 | 0.78 | 1120 | 0.88 |
| 1600             | 730                       | 0.33 | 790  | 0.40 | 850  | 0.48 | 910                              | 0.55 | 970  | 0.65 | 1025 | 0.73 | 1085 | 0.83 | 1140 | 0.93 |
| 1700             | 765                       | 0.40 | 825  | 0.48 | 880  | 0.53 | 935                              | 0.60 | 995  | 0.70 | 1050 | 0.80 | 1105 | 0.90 | 1155 | 1.03 |
| 1800             | 805                       | 0.48 | 860  | 0.53 | 910  | 0.60 | 970                              | 0.70 | 1020 | 0.80 | 1075 | 0.88 | 1125 | 0.98 | 1175 | 1.08 |
| 1900             | 845                       | 0.53 | 895  | 0.63 | 945  | 0.68 | 995                              | 0.78 | 1050 | 0.85 | 1100 | 0.95 | 1150 | 1.08 | 1200 | 1.18 |
| 2000             | 885                       | 0.63 | 930  | 0.68 | 980  | 0.78 | 1030                             | 0.88 | 1080 | 0.95 | 1125 | 1.05 | 1175 | 1.15 | 1220 | 1.28 |

0.90 to 1.60 in. w.g.

4 Ton Standard Efficiency (Down-Flow)

KHA048S

| Air Volume (cfm) | External Static (in.w.g.)         |      |      |      |      |      |      |      |      |      |      |      |      |              |      |      |
|------------------|-----------------------------------|------|------|------|------|------|------|------|------|------|------|------|------|--------------|------|------|
|                  | 0.90                              |      | 1.00 |      | 1.10 |      | 1.20 |      | 1.30 |      | 1.40 |      | 1.50 |              | 1.60 |      |
|                  | RPM                               | BHP  | RPM  | BHP  | RPM  | BHP  | RPM  | BHP  | RPM  | BHP  | RPM  | BHP  | RPM  | BHP          | RPM  | BHP  |
|                  | <b>High Static - Drive Kit #6</b> |      |      |      |      |      |      |      |      |      |      |      |      | <b>Field</b> |      |      |
| 1200             | 1135                              | 0.83 | 1190 | 0.95 | 1240 | 1.05 | 1290 | 1.20 | 1335 | 1.30 | 1380 | 1.43 | 1425 | 1.58         | 1470 | 1.70 |
| 1300             | 1145                              | 0.88 | 1200 | 1.00 | 1250 | 1.10 | 1300 | 1.25 | 1350 | 1.38 | 1395 | 1.50 | 1440 | 1.63         | 1480 | 1.78 |
| 1400             | 1160                              | 0.93 | 1215 | 1.05 | 1265 | 1.18 | 1310 | 1.30 | 1360 | 1.43 | 1405 | 1.57 | 1450 | 1.68         | 1490 | 1.83 |
| 1500             | 1175                              | 0.98 | 1225 | 1.10 | 1275 | 1.25 | 1325 | 1.35 | 1370 | 1.50 | 1415 | 1.63 | 1460 | 1.78         | 1500 | 1.93 |
| 1600             | 1190                              | 1.08 | 1240 | 1.18 | 1290 | 1.30 | 1340 | 1.45 | 1385 | 1.55 | 1430 | 1.70 | 1470 | 1.83         | 1515 | 2.00 |
| 1700             | 1205                              | 1.13 | 1260 | 1.25 | 1305 | 1.38 | 1355 | 1.50 | 1400 | 1.65 | 1440 | 1.78 | 1485 | 1.93         | 1525 | 2.08 |
| 1800             | 1225                              | 1.23 | 1275 | 1.33 | 1320 | 1.45 | 1370 | 1.60 | 1415 | 1.75 | 1455 | 1.85 | 1500 | 2.03         | 1540 | 2.18 |
| 1900             | 1245                              | 1.28 | 1290 | 1.43 | 1340 | 1.55 | 1385 | 1.70 | 1425 | 1.80 | 1470 | 1.95 | 1510 | 2.10         | 1555 | 2.28 |
| 2000             | 1270                              | 1.38 | 1315 | 1.53 | 1355 | 1.65 | 1400 | 1.78 | 1445 | 1.93 | 1485 | 2.05 | 1525 | 2.20         | 1565 | 2.38 |

0.10 to 0.80 in. w.g.

4 Ton Standard Efficiency (Horizontal)

KHA048S

| Air Volume (cfm) | External Static (in.w.g.) |      |      |      |      |      |                                  |      |      |      |      |      |      |      |      |      |
|------------------|---------------------------|------|------|------|------|------|----------------------------------|------|------|------|------|------|------|------|------|------|
|                  | 0.10                      |      | 0.20 |      | 0.30 |      | 0.40                             |      | 0.50 |      | 0.60 |      | 0.70 |      | 0.80 |      |
|                  | RPM                       | BHP  | RPM  | BHP  | RPM  | BHP  | RPM                              | BHP  | RPM  | BHP  | RPM  | BHP  | RPM  | BHP  | RPM  | BHP  |
|                  | <b>Field Furnished</b>    |      |      |      |      |      | <b>Low Static - Drive Kit #2</b> |      |      |      |      |      |      |      |      |      |
| 1200             | 590                       | 0.18 | 655  | 0.20 | 720  | 0.25 | 780                              | 0.35 | 845  | 0.40 | 905  | 0.50 | 965  | 0.58 | 1020 | 0.68 |
| 1300             | 630                       | 0.20 | 685  | 0.25 | 745  | 0.30 | 805                              | 0.38 | 865  | 0.45 | 925  | 0.52 | 980  | 0.60 | 1034 | 0.70 |
| 1400             | 675                       | 0.25 | 725  | 0.30 | 780  | 0.35 | 835                              | 0.43 | 890  | 0.50 | 945  | 0.53 | 995  | 0.65 | 1050 | 0.75 |
| 1500             | 715                       | 0.33 | 760  | 0.35 | 810  | 0.40 | 860                              | 0.50 | 914  | 0.55 | 965  | 0.63 | 1015 | 0.73 | 1065 | 0.80 |
| 1600             | 755                       | 0.38 | 800  | 0.43 | 845  | 0.48 | 895                              | 0.55 | 940  | 0.60 | 990  | 0.70 | 1040 | 0.80 | 1085 | 0.88 |
| 1700             | 795                       | 0.45 | 835  | 0.50 | 880  | 0.55 | 925                              | 0.63 | 970  | 0.70 | 1015 | 0.78 | 1060 | 0.85 | 1105 | 0.95 |
| 1800             | 840                       | 0.53 | 875  | 0.58 | 915  | 0.63 | 960                              | 0.70 | 1000 | 0.78 | 1045 | 0.85 | 1085 | 0.93 | 1130 | 1.03 |
| 1900             | 880                       | 0.63 | 920  | 0.68 | 955  | 0.73 | 995                              | 0.80 | 1035 | 0.88 | 1075 | 0.95 | 1115 | 1.03 | 1155 | 1.13 |
| 2000             | 925                       | 0.73 | 960  | 0.78 | 995  | 0.83 | 1030                             | 0.90 | 1070 | 0.98 | 1105 | 1.05 | 1145 | 1.13 | 1180 | 1.23 |

0.90 to 1.60 in. w.g.

4 Ton Standard Efficiency (Horizontal)

KHA048S

| Air Volume (cfm) | External Static (in.w.g.) |      |      |      |      |      |                                   |      |      |      |      |      |      |      |      |      |
|------------------|---------------------------|------|------|------|------|------|-----------------------------------|------|------|------|------|------|------|------|------|------|
|                  | 0.90                      |      | 1.0  |      | 1.10 |      | 1.20                              |      | 1.30 |      | 1.40 |      | 1.50 |      | 1.60 |      |
|                  | RPM                       | BHP  | RPM  | BHP  | RPM  | BHP  | RPM                               | BHP  | RPM  | BHP  | RPM  | BHP  | RPM  | BHP  | RPM  | BHP  |
|                  | <b>Kit #2</b>             |      |      |      |      |      | <b>High Static - Drive Kit #6</b> |      |      |      |      |      |      |      |      |      |
| 1200             | 1070                      | 0.75 | 1120 | 0.85 | 1170 | 0.98 | 1215                              | 1.08 | 1255 | 1.18 | 1300 | 1.30 | 1340 | 1.40 | 1380 | 1.55 |
| 1300             | 1085                      | 0.80 | 1135 | 0.90 | 1180 | 1.00 | 1225                              | 1.13 | 1270 | 1.23 | 1310 | 1.35 | 1350 | 1.48 | 1390 | 1.60 |
| 1400             | 1100                      | 0.85 | 1145 | 0.98 | 1195 | 1.08 | 1240                              | 1.18 | 1280 | 1.28 | 1324 | 1.43 | 1365 | 1.53 | 1405 | 1.68 |
| 1500             | 1115                      | 0.90 | 1160 | 1.03 | 1205 | 1.13 | 1250                              | 1.23 | 1295 | 1.35 | 1335 | 1.48 | 1375 | 1.63 | 1415 | 1.73 |
| 1600             | 1130                      | 0.98 | 1175 | 1.08 | 1220 | 1.18 | 1265                              | 1.33 | 1305 | 1.43 | 1350 | 1.55 | 1390 | 1.68 | 1425 | 1.80 |
| 1700             | 1150                      | 1.05 | 1195 | 1.15 | 1240 | 1.28 | 1280                              | 1.38 | 1320 | 1.50 | 1365 | 1.63 | 1400 | 1.75 | 1440 | 1.88 |
| 1800             | 1170                      | 1.13 | 1215 | 1.23 | 1255 | 1.35 | 1300                              | 1.48 | 1340 | 1.58 | 1380 | 1.73 | 1415 | 1.83 | 1455 | 1.98 |
| 1900             | 1195                      | 1.23 | 1235 | 1.33 | 1275 | 1.43 | 1315                              | 1.55 | 1355 | 1.68 | 1395 | 1.78 | 1435 | 1.93 | 1470 | 2.08 |
| 2000             | 1220                      | 1.33 | 1260 | 1.43 | 1300 | 1.53 | 1340                              | 1.68 | 1375 | 1.78 | 1415 | 1.93 | 1450 | 2.03 | 1485 | 2.18 |

**TABLE 5  
BELT DRIVE BLOWER PERFORMANCE**

| 0.10 to 0.80 in. w.g. |                                  | 5 Ton Standard Efficiency (Down-Flow)  |                                   |      |      |      |                                   |      |      |      |      |      |      |      |      | KHA060S |
|-----------------------|----------------------------------|--|-----------------------------------|------|------|------|-----------------------------------|------|------|------|------|------|------|------|------|---------|
| Air Volume (cfm)      | External Static (in.w.g.)        |  |                                   |      |      |      |                                   |      |      |      |      |      |      |      |      |         |
|                       | 0.10                             |  | 0.20                              |      | 0.30 |      | 0.40                              |      | 0.50 |      | 0.60 |      | 0.70 |      | 0.80 |         |
|                       | RPM                              | BHP                                    | RPM                               | BHP  | RPM  | BHP  | RPM                               | BHP  | RPM  | BHP  | RPM  | BHP  | RPM  | BHP  | RPM  | BHP     |
|                       | <b>Field Furnished</b>           |  |                                   |      |      |      | <b>Low Static - Drive Kit #3</b>  |      |      |      |      |      |      |      |      |         |
| 1600                  | 675                              | 0.30                                   | 730                               | 0.35 | 785  | 0.40 | 835                               | 0.45 | 885  | 0.50 | 935  | 0.60 | 985  | 0.65 | 1030 | 0.70    |
| 1700                  | 710                              | 0.35                                   | 760                               | 0.40 | 815  | 0.45 | 860                               | 0.50 | 910  | 0.60 | 960  | 0.65 | 1005 | 0.70 | 1050 | 0.80    |
| 1800                  | 745                              | 0.45                                   | 795                               | 0.50 | 845  | 0.55 | 890                               | 0.60 | 935  | 0.65 | 980  | 0.70 | 1025 | 0.80 | 1070 | 0.85    |
| 1900                  | 780                              | 0.50                                   | 830                               | 0.55 | 875  | 0.60 | 920                               | 0.65 | 965  | 0.75 | 1010 | 0.80 | 1050 | 0.85 | 1090 | 0.95    |
| 2000                  | 820                              | 0.60                                   | 865                               | 0.65 | 905  | 0.70 | 950                               | 0.75 | 990  | 0.80 | 1035 | 0.90 | 1075 | 0.95 | 1115 | 1.05    |
| 2100                  | 855                              | 0.65                                   | 900                               | 0.70 | 940  | 0.80 | 980                               | 0.85 | 1020 | 0.90 | 1060 | 1.00 | 1100 | 1.05 | 1140 | 1.15    |
| 2200                  | 890                              | 0.75                                   | 935                               | 0.80 | 970  | 0.85 | 1010                              | 0.95 | 1050 | 1.00 | 1090 | 1.10 | 1130 | 1.15 | 1165 | 1.25    |
| 2300                  | 930                              | 0.85                                   | 970                               | 0.90 | 1005 | 1.00 | 1045                              | 1.05 | 1080 | 1.10 | 1120 | 1.20 | 1155 | 1.25 | 1190 | 1.35    |
| 2400                  | 965                              | 0.95                                   | 1005                              | 1.05 | 1040 | 1.10 | 1075                              | 1.15 | 1115 | 1.25 | 1150 | 1.30 | 1185 | 1.40 | 1220 | 1.50    |
| 0.90 to 1.60 in. w.g. |                                  | 5 Ton Standard Efficiency (Down-Flow)  |                                   |      |      |      |                                   |      |      |      |      |      |      |      |      | KHA060S |
| Air Volume (cfm)      | External Static (in.w.g.)        |  |                                   |      |      |      |                                   |      |      |      |      |      |      |      |      |         |
|                       | 0.90                             |  | 1.00                              |      | 1.10 |      | 1.20                              |      | 1.30 |      | 1.40 |      | 1.50 |      | 1.60 |         |
|                       | RPM                              | BHP                                    | RPM                               | BHP  | RPM  | BHP  | RPM                               | BHP  | RPM  | BHP  | RPM  | BHP  | RPM  | BHP  | RPM  | BHP     |
|                       | <b>Low Static - Drive Kit #3</b> |  |                                   |      |      |      | <b>High Static - Drive Kit #7</b> |      |      |      |      |      |      |      |      |         |
| 1600                  | 1075                             | 0.80                                   | 1120                              | 0.85 | 1160 | 0.95 | 1200                              | 1.05 | 1240 | 1.10 | 1280 | 1.20 | 1320 | 1.30 | 1355 | 1.35    |
| 1700                  | 1090                             | 0.85                                   | 1135                              | 0.95 | 1175 | 1.00 | 1215                              | 1.10 | 1255 | 1.20 | 1295 | 1.30 | 1330 | 1.35 | 1365 | 1.45    |
| 1800                  | 1110                             | 0.95                                   | 1155                              | 1.00 | 1195 | 1.10 | 1230                              | 1.20 | 1270 | 1.25 | 1310 | 1.35 | 1345 | 1.45 | 1380 | 1.55    |
| 1900                  | 1135                             | 1.05                                   | 1170                              | 1.10 | 1210 | 1.20 | 1250                              | 1.25 | 1285 | 1.35 | 1325 | 1.45 | 1360 | 1.55 | 1395 | 1.65    |
| 2000                  | 1155                             | 1.10                                   | 1195                              | 1.20 | 1230 | 1.30 | 1270                              | 1.35 | 1305 | 1.45 | 1340 | 1.55 | 1375 | 1.65 | 1410 | 1.75    |
| 2100                  | 1180                             | 1.20                                   | 1215                              | 1.30 | 1250 | 1.40 | 1290                              | 1.45 | 1325 | 1.55 | 1360 | 1.65 | 1395 | 1.75 | 1425 | 1.85    |
| 2200                  | 1200                             | 1.30                                   | 1240                              | 1.40 | 1275 | 1.50 | 1310                              | 1.60 | 1345 | 1.70 | 1380 | 1.80 | 1410 | 1.85 | 1445 | 1.95    |
| 2300                  | 1225                             | 1.45                                   | 1260                              | 1.50 | 1295 | 1.60 | 1330                              | 1.70 | 1365 | 1.80 | 1400 | 1.90 | 1430 | 2.00 | 1465 | 2.10    |
| 2400                  | 1255                             | 1.55                                   | 1285                              | 1.65 | 1320 | 1.75 | 1355                              | 1.85 | 1385 | 1.90 | 1420 | 2.05 | 1450 | 2.10 | 1480 | 2.20    |
| 0.10 to 0.80 in. w.g. |                                  | 5 Ton Standard Efficiency (Horizontal) |                                   |      |      |      |                                   |      |      |      |      |      |      |      |      | KHA060S |
| Air Volume (cfm)      | External Static (in.w.g.)        |  |                                   |      |      |      |                                   |      |      |      |      |      |      |      |      |         |
|                       | 0.10                             |  | 0.20                              |      | 0.30 |      | 0.40                              |      | 0.50 |      | 0.60 |      | 0.70 |      | 0.80 |         |
|                       | RPM                              | BHP                                    | RPM                               | BHP  | RPM  | BHP  | RPM                               | BHP  | RPM  | BHP  | RPM  | BHP  | RPM  | BHP  | RPM  | BHP     |
|                       | <b>Field</b>                     |  | <b>Low Static - Drive Kit #3</b>  |      |      |      |                                   |      |      |      |      |      |      |      |      |         |
| 1600                  | 785                              | 0.40                                   | 845                               | 0.45 | 900  | 0.50 | 955                               | 0.55 | 1010 | 0.65 | 1060 | 0.70 | 1110 | 0.80 | 1160 | 0.90    |
| 1700                  | 825                              | 0.45                                   | 880                               | 0.50 | 935  | 0.60 | 990                               | 0.65 | 1040 | 0.70 | 1090 | 0.80 | 1135 | 0.85 | 1185 | 0.95    |
| 1800                  | 865                              | 0.50                                   | 920                               | 0.60 | 975  | 0.65 | 1020                              | 0.75 | 1070 | 0.80 | 1120 | 0.90 | 1165 | 0.95 | 1210 | 1.05    |
| 1900                  | 910                              | 0.60                                   | 960                               | 0.70 | 1010 | 0.75 | 1060                              | 0.85 | 1105 | 0.90 | 1150 | 1.00 | 1195 | 1.05 | 1240 | 1.15    |
| 2000                  | 950                              | 0.70                                   | 1000                              | 0.80 | 1050 | 0.85 | 1095                              | 0.95 | 1140 | 1.00 | 1185 | 1.10 | 1225 | 1.15 | 1265 | 1.25    |
| 2100                  | 995                              | 0.80                                   | 1040                              | 0.90 | 1085 | 0.95 | 1130                              | 1.05 | 1175 | 1.15 | 1215 | 1.20 | 1260 | 1.30 | 1300 | 1.40    |
| 2200                  | 1040                             | 0.95                                   | 1085                              | 1.00 | 1125 | 1.10 | 1170                              | 1.15 | 1210 | 1.25 | 1250 | 1.35 | 1290 | 1.40 | 1330 | 1.50    |
| 2300                  | 1080                             | 1.05                                   | 1125                              | 1.15 | 1165 | 1.20 | 1205                              | 1.30 | 1245 | 1.40 | 1285 | 1.45 | 1325 | 1.55 | 1360 | 1.65    |
| 2400                  | 1125                             | 1.20                                   | 1165                              | 1.25 | 1205 | 1.35 | 1245                              | 1.45 | 1285 | 1.55 | 1320 | 1.60 | 1360 | 1.70 | 1395 | 1.80    |
| 0.90 to 1.60 in. w.g. |                                  | 5 Ton Standard Efficiency (Horizontal) |                                   |      |      |      |                                   |      |      |      |      |      |      |      |      | KHA060S |
| Air Volume (cfm)      | External Static (in.w.g.)        |  |                                   |      |      |      |                                   |      |      |      |      |      |      |      |      |         |
|                       | 0.90                             |  | 1.00                              |      | 1.10 |      | 1.20                              |      | 1.30 |      | 1.40 |      | 1.50 |      | 1.60 |         |
|                       | RPM                              | BHP                                    | RPM                               | BHP  | RPM  | BHP  | RPM                               | BHP  | RPM  | BHP  | RPM  | BHP  | RPM  | BHP  | RPM  | BHP     |
|                       | <b>Drive Kit #3</b>              |  | <b>High Static - Drive Kit #7</b> |      |      |      |                                   |      |      |      |      |      |      |      |      |         |
| 1600                  | 1210                             | 0.95                                   | 1255                              | 1.05 | 1305 | 1.15 | 1350                              | 1.30 | 1395 | 1.40 | 1440 | 1.55 | 1485 | 1.65 | 1530 | 1.80    |
| 1700                  | 1230                             | 1.05                                   | 1275                              | 1.15 | 1320 | 1.25 | 1365                              | 1.35 | 1410 | 1.45 | 1455 | 1.60 | 1495 | 1.70 | 1540 | 1.85    |
| 1800                  | 1255                             | 1.15                                   | 1300                              | 1.25 | 1340 | 1.35 | 1385                              | 1.45 | 1425 | 1.55 | 1470 | 1.70 | 1510 | 1.80 | 1550 | 1.95    |
| 1900                  | 1280                             | 1.25                                   | 1325                              | 1.35 | 1365 | 1.45 | 1405                              | 1.55 | 1445 | 1.65 | 1485 | 1.75 | 1525 | 1.90 | 1565 | 2.00    |
| 2000                  | 1310                             | 1.35                                   | 1350                              | 1.45 | 1390 | 1.55 | 1430                              | 1.65 | 1470 | 1.75 | 1505 | 1.85 | 1545 | 2.00 | 1585 | 2.15    |
| 2100                  | 1340                             | 1.50                                   | 1375                              | 1.55 | 1415 | 1.65 | 1455                              | 1.80 | 1490 | 1.90 | 1530 | 2.00 | 1565 | 2.10 | 1605 | 2.25    |
| 2200                  | 1370                             | 1.60                                   | 1405                              | 1.70 | 1445 | 1.80 | 1480                              | 1.90 | 1515 | 2.00 | 1555 | 2.15 | 1590 | 2.25 | 1625 | 2.40    |
| 2300                  | 1400                             | 1.75                                   | 1435                              | 1.85 | 1470 | 1.95 | 1510                              | 2.05 | 1545 | 2.20 | 1580 | 2.30 | 1615 | 2.40 | 1650 | 2.55    |
| 2400                  | 1430                             | 1.90                                   | 1465                              | 2.00 | 1505 | 2.15 | 1535                              | 2.20 | 1570 | 2.35 | 1605 | 2.45 | 1640 | 2.60 | 1675 | 2.70    |

**TABLE 6  
BELT DRIVE BLOWER PERFORMANCE**

0.10 to 0.80 in. w.g.

6 Ton Standard Efficiency (Downflow)

KHA072S

| Air Volume (cfm) | External Static (in.w.g.) |             |             |      |             |      |             |      |             |      |                                   |      |             |             |             |             |
|------------------|---------------------------|-------------|-------------|------|-------------|------|-------------|------|-------------|------|-----------------------------------|------|-------------|-------------|-------------|-------------|
|                  | 0.10                      |             | 0.20        |      | 0.30        |      | 0.40        |      | 0.50        |      | 0.60                              |      | 0.70        |             | 0.80        |             |
|                  | RPM                       | BHP         | RPM         | BHP  | RPM         | BHP  | RPM         | BHP  | RPM         | BHP  | RPM                               | BHP  | RPM         | BHP         | RPM         | BHP         |
|                  | <b>Field Furnished</b>    |             |             |      |             |      |             |      |             |      | <b>Low Static - Drive Kit A04</b> |      |             |             |             |             |
| 1900             | 752                       | 0.48        | 803         | 0.53 | 855         | 0.58 | 903         | 0.62 | 957         | 0.72 | 1008                              | 0.78 | 1066        | 0.88        | 1118        | 0.92        |
| 2000             | 793                       | 0.52        | 845         | 0.62 | 892         | 0.68 | 940         | 0.73 | <b>990</b>  | 0.77 | 1041                              | 0.88 | 1093        | 0.93        | 1144        | 1.03        |
| 2100             | 838                       | 0.64        | 881         | 0.68 | 929         | 0.73 | <b>978</b>  | 0.83 | 1023        | 0.88 | 1073                              | 0.93 | 1124        | 1.03        | 1169        | 1.14        |
| 2200             | 880                       | 0.73        | 923         | 0.78 | 966         | 0.84 | <b>1015</b> | 0.93 | 1061        | 0.99 | 1104                              | 1.03 | 1149        | 1.13        | 1198        | 1.24        |
| 2300             | 921                       | 0.83        | 966         | 0.89 | <b>1009</b> | 0.93 | 1053        | 0.99 | 1097        | 1.09 | 1139                              | 1.15 | 1183        | 1.25        | 1220        | 1.35        |
| 2400             | <b>964</b>                | <b>0.94</b> | <b>1007</b> | 0.99 | 1046        | 1.05 | 1089        | 1.14 | 1127        | 1.19 | 1168                              | 1.29 | 1211        | 1.35        | 1247        | 1.45        |
| 2500             | 1006                      | 1.05        | 1044        | 1.09 | 1087        | 1.14 | 1124        | 1.25 | 1160        | 1.30 | 1201                              | 1.40 | 1238        | 1.51        | 1274        | 1.56        |
| 2600             | 1047                      | 1.15        | 1085        | 1.20 | 1121        | 1.30 | 1157        | 1.36 | 1197        | 1.46 | 1234                              | 1.56 | 1269        | 1.62        | 1304        | 1.72        |
| 2700             | 1094                      | 1.31        | 1124        | 1.37 | 1159        | 1.41 | 1195        | 1.52 | 1229        | 1.62 | 1265                              | 1.67 | <b>1295</b> | <b>1.77</b> | <b>1330</b> | <b>1.88</b> |
| 2800             | 1133                      | 1.42        | 1162        | 1.52 | 1196        | 1.57 | 1226        | 1.67 | <b>1260</b> | 1.73 | 1295                              | 1.83 | 1325        | 1.94        | 1360        | 2.04        |
| 2900             | 1170                      | 1.58        | 1204        | 1.68 | <b>1232</b> | 1.73 | 1261        | 1.84 | 1290        | 1.89 | 1326                              | 2.00 | 1356        | 2.09        | 1386        | 2.19        |

0.90 to 1.60 in. w.g.

6 Ton Standard Efficiency (Downflow)

KHA072S

| Air Volume (cfm) | External Static (in.w.g.)    |      |             |             |             |             |             |             |             |             |             |             |             |             |             |             |
|------------------|------------------------------|------|-------------|-------------|-------------|-------------|-------------|-------------|-------------|-------------|-------------|-------------|-------------|-------------|-------------|-------------|
|                  | 0.90                         |      | 1.00        |             | 1.10        |             | 1.20        |             | 1.30        |             | 1.40        |             | 1.50        |             | 1.60        |             |
|                  | RPM                          | BHP  | RPM         | BHP         | RPM         | BHP         | RPM         | BHP         | RPM         | BHP         | RPM         | BHP         | RPM         | BHP         | RPM         | BHP         |
|                  | <b>High Static - Kit A08</b> |      |             |             |             |             |             |             |             |             |             |             |             |             |             |             |
| 1900             | 1170                         | 1.03 | 1216        | 1.12        | 1261        | 1.23        | 1299        | 1.28        | 1338        | 1.39        | 1381        | 1.49        | 1423        | 1.59        | 1462        | 1.69        |
| 2000             | 1190                         | 1.13 | 1238        | 1.18        | 1279        | 1.28        | 1317        | 1.39        | 1356        | 1.49        | 1397        | 1.59        | 1434        | 1.69        | 1476        | 1.80        |
| 2100             | 1213                         | 1.19 | 1261        | 1.29        | 1300        | 1.39        | 1339        | 1.49        | 1373        | 1.60        | 1414        | 1.70        | 1449        | 1.79        | 1490        | 1.90        |
| 2200             | 1241                         | 1.30 | 1282        | 1.39        | 1316        | 1.50        | 1355        | 1.60        | 1394        | 1.70        | 1429        | 1.79        | 1463        | 1.90        | 1498        | 1.99        |
| 2300             | 1263                         | 1.39 | 1303        | 1.50        | 1337        | 1.60        | 1376        | 1.70        | 1409        | 1.80        | 1444        | 1.90        | 1483        | 2.04        | 1517        | 2.14        |
| 2400             | 1289                         | 1.55 | 1323        | 1.61        | 1362        | 1.76        | 1397        | 1.86        | 1430        | 1.96        | 1464        | 2.05        | 1498        | 2.15        | 1532        | 2.25        |
| 2500             | 1314                         | 1.66 | 1349        | 1.76        | 1383        | 1.87        | 1416        | 1.96        | 1451        | 2.06        | 1484        | 2.15        | 1517        | 2.24        | <b>1545</b> | 2.34        |
| 2600             | 1340                         | 1.82 | 1374        | 1.92        | 1408        | 2.02        | 1438        | 2.12        | 1471        | 2.21        | 1505        | 2.30        | <b>1532</b> | <b>2.39</b> | <b>1565</b> | <b>2.49</b> |
| 2700             | 1365                         | 1.98 | 1399        | 2.08        | 1429        | 2.12        | <b>1463</b> | <b>2.27</b> | <b>1497</b> | <b>2.36</b> | <b>1525</b> | <b>2.45</b> | <b>1558</b> | <b>2.55</b> | <b>1585</b> | <b>2.63</b> |
| 2800             | 1390                         | 2.08 | 1425        | 2.24        | 1454        | 2.27        | <b>1488</b> | <b>2.42</b> | <b>1517</b> | <b>2.51</b> | <b>1545</b> | <b>2.60</b> | <b>1578</b> | <b>2.69</b> | <b>1605</b> | <b>2.84</b> |
| 2900             | 1421                         | 2.28 | <b>1451</b> | <b>2.39</b> | <b>1480</b> | <b>2.47</b> | <b>1514</b> | <b>2.57</b> | <b>1543</b> | <b>2.65</b> | <b>1570</b> | <b>2.75</b> | <b>1597</b> | <b>2.89</b> | <b>1625</b> | <b>2.99</b> |

Note - **BOLD** - to operate in this range, 3 hp blower motor is required.



**TABLE 7  
BELT DRIVE BLOWER PERFORMANCE**

0.10 to 0.80 in. w.g.

6 Ton Standard Efficiency (Horizontal)

KHA072S

| Air Volume (cfm) | External Static (in.w.g.) |      |                                   |      |      |      |      |      |      |      |      |      |      |      |      |      |
|------------------|---------------------------|------|-----------------------------------|------|------|------|------|------|------|------|------|------|------|------|------|------|
|                  | 0.10                      |      | 0.20                              |      | 0.30 |      | 0.40 |      | 0.50 |      | 0.60 |      | 0.70 |      | 0.80 |      |
|                  | RPM                       | BHP  | RPM                               | BHP  | RPM  | BHP  | RPM  | BHP  | RPM  | BHP  | RPM  | BHP  | RPM  | BHP  | RPM  | BHP  |
|                  | <b>Field</b>              |      | <b>Low Static - Drive Kit A04</b> |      |      |      |      |      |      |      |      |      |      |      |      |      |
| 1900             | 919                       | 0.60 | 969                               | 0.65 | 1020 | 0.74 | 1065 | 0.79 | 1111 | 0.83 | 1154 | 0.93 | 1194 | 0.99 | 1232 | 1.04 |
| 2000             | 962                       | 0.70 | 1013                              | 0.75 | 1058 | 0.84 | 1103 | 0.90 | 1148 | 0.94 | 1186 | 1.04 | 1226 | 1.09 | 1264 | 1.15 |
| 2100             | 1010                      | 0.80 | 1056                              | 0.85 | 1101 | 0.95 | 1146 | 0.99 | 1185 | 1.05 | 1223 | 1.15 | 1262 | 1.20 | 1296 | 1.30 |
| 2200             | 1054                      | 0.91 | 1099                              | 0.95 | 1143 | 1.06 | 1183 | 1.10 | 1222 | 1.21 | 1261 | 1.25 | 1295 | 1.36 | 1333 | 1.41 |
| 2300             | 1102                      | 1.01 | 1142                              | 1.11 | 1182 | 1.16 | 1220 | 1.26 | 1258 | 1.31 | 1297 | 1.42 | 1330 | 1.46 | 1364 | 1.57 |
| 2400             | 1146                      | 1.16 | 1184                              | 1.21 | 1224 | 1.32 | 1262 | 1.37 | 1300 | 1.47 | 1333 | 1.58 | 1367 | 1.63 | 1401 | 1.72 |
| 2500             | 1188                      | 1.27 | 1227                              | 1.38 | 1265 | 1.48 | 1303 | 1.53 | 1336 | 1.63 | 1370 | 1.73 | 1404 | 1.79 | 1438 | 1.88 |
| 2600             | 1235                      | 1.44 | 1273                              | 1.55 | 1306 | 1.65 | 1339 | 1.70 | 1378 | 1.79 | 1407 | 1.89 | 1441 | 1.99 | 1475 | 2.03 |
| 2700             | 1276                      | 1.61 | 1314                              | 1.71 | 1347 | 1.81 | 1380 | 1.91 | 1414 | 2.00 | 1449 | 2.05 | 1478 | 2.14 | 1512 | 2.23 |
| 2800             | 1321                      | 1.82 | 1354                              | 1.92 | 1388 | 1.97 | 1421 | 2.07 | 1456 | 2.16 | 1485 | 2.25 | 1519 | 2.34 | 1549 | 2.44 |
| 2900             | 1367                      | 2.03 | 1400                              | 2.08 | 1429 | 2.17 | 1463 | 2.27 | 1497 | 2.36 | 1526 | 2.45 | 1556 | 2.54 | 1586 | 2.63 |

0.90 to 1.60 in. w.g.

6 Ton Standard Efficiency (Horizontal)

KHA072S

| Air Volume (cfm) | External Static (in.w.g.) |      |      |      |                              |      |      |      |      |      |      |      |      |      |      |      |
|------------------|---------------------------|------|------|------|------------------------------|------|------|------|------|------|------|------|------|------|------|------|
|                  | 0.90                      |      | 1.00 |      | 1.10                         |      | 1.20 |      | 1.30 |      | 1.40 |      | 1.50 |      | 1.60 |      |
|                  | RPM                       | BHP  | RPM  | BHP  | RPM                          | BHP  | RPM  | BHP  | RPM  | BHP  | RPM  | BHP  | RPM  | BHP  | RPM  | BHP  |
|                  | <b>Drive Kit A04</b>      |      |      |      | <b>High Static - Kit A08</b> |      |      |      |      |      |      |      |      |      |      |      |
| 1900             | 1271                      | 1.13 | 1310 | 1.18 | 1345                         | 1.24 | 1380 | 1.34 | 1421 | 1.39 | 1458 | 1.50 | 1493 | 1.60 | 1524 | 1.65 |
| 2000             | 1303                      | 1.24 | 1337 | 1.29 | 1371                         | 1.40 | 1412 | 1.45 | 1448 | 1.55 | 1485 | 1.61 | 1516 | 1.70 | 1551 | 1.75 |
| 2100             | 1335                      | 1.36 | 1370 | 1.45 | 1404                         | 1.50 | 1439 | 1.60 | 1476 | 1.65 | 1512 | 1.76 | 1544 | 1.81 | 1579 | 1.90 |
| 2200             | 1367                      | 1.51 | 1401 | 1.56 | 1436                         | 1.66 | 1472 | 1.71 | 1503 | 1.81 | 1540 | 1.91 | 1570 | 1.96 | 1606 | 2.06 |
| 2300             | 1398                      | 1.62 | 1433 | 1.71 | 1468                         | 1.81 | 1503 | 1.86 | 1535 | 1.97 | 1567 | 2.02 | 1603 | 2.11 | 1633 | 2.21 |
| 2400             | 1436                      | 1.78 | 1470 | 1.87 | 1501                         | 1.96 | 1535 | 2.01 | 1567 | 2.12 | 1600 | 2.22 | 1630 | 2.27 | 1660 | 2.36 |
| 2500             | 1473                      | 1.98 | 1503 | 2.03 | 1533                         | 2.12 | 1568 | 2.21 | 1599 | 2.27 | 1631 | 2.37 | 1662 | 2.47 | 1693 | 2.57 |
| 2600             | 1505                      | 2.13 | 1539 | 2.23 | 1570                         | 2.32 | 1600 | 2.37 | 1632 | 2.47 | 1664 | 2.57 | 1694 | 2.67 | 1725 | 2.77 |
| 2700             | 1542                      | 2.33 | 1572 | 2.37 | 1607                         | 2.47 | 1638 | 2.57 | 1664 | 2.67 | 1696 | 2.77 | 1726 | 2.87 | 1757 | 2.97 |
| 2800             | 1579                      | 2.53 | 1609 | 2.58 | 1640                         | 2.68 | 1670 | 2.77 | 1701 | 2.87 | 1732 | 2.96 | 1758 | 3.07 | 1789 | 3.16 |
| 2900             | 1616                      | 2.73 | 1646 | 2.83 | 1676                         | 2.92 | 1708 | 3.02 | 1733 | 3.06 | 1764 | 3.17 | 1794 | 3.31 | 1821 | 3.37 |

Note - **BOLD** - to operate in this range, 3 hp blower motor is required.

**TABLE 8  
ADDITIONAL ACCESSORY AIR RESISTANCE**

| Air Volume<br>cfm | Economizer | Electric Heat |
|-------------------|------------|---------------|
| 800               | 0.04       | 0.01          |
| 1000              | 0.04       | 0.03          |
| 1200              | 0.04       | 0.06          |
| 1400              | 0.04       | 0.09          |
| 1600              | 0.04       | 0.12          |
| 1800              | 0.05       | 0.15          |
| 2000              | 0.05       | 0.18          |
| 2200              | 0.05       | 0.20          |
| 2400              | 0.05       | 0.22          |
| 2600              | 0.06       | 0.24          |
| 2800              | 0.06       | 0.26          |
| 3000              | 0.06       | 0.28          |

**TABLE 9  
MINIMUM AIRFLOW  
KH(BELT DRIVE) UNITS WITH ELECTRIC HEAT**

| Kw   | CFM      |            |
|------|----------|------------|
|      | Downflow | Horizontal |
| 30   | 2250     | 2050       |
| 22.5 | 1750     | 1800       |
| 15   | 1250     | 1350       |
| 7.5  | 1050     | 1200       |

Direct drive units with electric heat (7.5-22.5kW) can operate on low speed up to 0.6" w.g. maximum static pressure.

**TABLE 10  
DRIVE COMPONENT MANUFACTURER'S NUMBERS**

| Drive No. | DRIVE COMPONENTS |              |               |              |              |              |
|-----------|------------------|--------------|---------------|--------------|--------------|--------------|
|           | MOTOR PULLEY     |              | BLOWER PULLEY |              | BELTS        |              |
|           | Browning No.     | OEM Part No. | Browning No.  | OEM Part No. | Browning No. | OEM Part No. |
| A01       | 1VP34 X 3/8      | 31K6901      | AK54 X 1      | 100244-19    | A40          | 100245-17    |
| A02       | 1VP34 X 3/8      | 31K6901      | AK49 X 1      | 100244-18    | A39          | 100245-16    |
| A03       | 1VP34 X 3/8      | 31K6901      | AK44X 1       | 100244-16    | A39          | 100245-16    |
| A04       | 1VP40 X 3/8      | 79J0301      | AK49 X 1      | 100244-18    | A41          | 100245-18    |
| A05       | 1VP34 X 3/8      | 31K6901      | AK41 X 1      | 100244-15    | A38          | 100245-15    |
| A06       | 1VP44 X 3/8      | P-8-1488     | AK51 X 1      | 18L2201      | A41          | 100245-18    |
| A07       | 1VP50 X 3/8      | 53J1501      | AK54 X 1      | 100244-19    | AX43         | 73K8201      |
| A08       | 1VP44 X 3/8      | P-8-1488     | AK46 X 1      | 100244-17    | A40          | 100245-17    |

**TABLE 11  
DRIVE KIT SPECIFICATIONS**

| Motor hp |         | RPM Range  |            |            |            |            |             |             |             |
|----------|---------|------------|------------|------------|------------|------------|-------------|-------------|-------------|
| Nominal  | Maximum | Drive A01  | Drive A02  | Drive A03  | Drive A04  | Drive A05  | Drive A06   | Drive A07   | Drive A08   |
| 1.5      | 1.72    | 673 - 1010 | 745 - 1117 | 833 - 1250 | 968 - 1340 | 897 - 1346 | 1071 - 1429 | 1212 - 1548 | 1193 - 1591 |
| 2        | 2.3     |            |            |            |            |            |             |             |             |

\*Using total air volume and system static pressure requirements determine from blower performance tables rpm and motor hp required. Maximum usable hp of motors furnished by Lennox are shown. In Canada, nominal motor hp is also maximum usable motor hp. If motors of comparable hp are used, be sure to keep within the service factor limitations outlined on the motor nameplate.

**Start-Up**

**▲ IMPORTANT**  
If unit is equipped with a crankcase heater. Make sure heater is energized 24 hours before unit start-up to prevent compressor damage as a result of slugging.

**A-Start-Up**

**Heating**

- 1- Set thermostat or temperature control device to initiate a first-stage heating demand.

- 2- A first-stage heating demand (W1) will energize compressors 1 and the outdoor fan.

*Note - L1 reversing valve is de-energized in the heating mode.*

*KHA Units With Optional Electric Heat -*

An increased heating demand (W2) will energize electric heat. Electric heat is also energized during the defrost cycle (W1) to maintain discharge air temperature.

**Cooling**

- 1- Set thermostat or temperature control device fan switch to **AUTO** or **ON**. Set thermostat or temperature control device to initiate a first-stage cooling demand.

A first-stage Y1 cooling demand will energize L1 reversing valve solenoid and compressor 1.

*Units With Optional Economizer -*

The optional economizer will start on a first stage (Y1) cooling demand when outdoor air enthalpy is suitable. An increased cooling demand (Y2) will energize compressor 1.

- 2- Refrigerant circuits are factory charged with either R-22 or R-410A refrigerant. See unit rating plate for correct amount of charge.

**B-Three Phase Scroll Compressor Voltage Phasing**

Three phase scroll compressors must be phased sequentially to ensure correct compressor and blower rotation and operation. Compressor and blower are wired in phase at the factory. Power wires are color-coded as follows: line 1-red, line 2-yellow, line 3-blue.

- 1- Observe suction and discharge pressures and blower rotation on unit start-up.
- 2- Suction pressure must drop, discharge pressure must rise, and blower rotation must match rotation marking.

If pressure differential is not observed or blower rotation is not correct:

- 3- Disconnect all remote electrical power supplies.
- 4- Reverse any two field-installed wires connected to the line side of K1 contactor. Do not reverse wires at blower contactor.

Make sure the connections are tight.

Discharge and suction pressures should operate at their normal start-up ranges.

**C - Refrigerant Charge and Check**

**WARNING-Do not exceed nameplate charge under any condition.**

This unit is factory charged and should require no further adjustment. If the system requires charge, **reclaim the charge, evacuate the system, and add required nameplate charge.**

*NOTE - System charging is not recommended below 60°F (15°C). In temperatures below 60°F (15°C) , the charge **must** be weighed into the system.*

If weighing facilities are not available, or to check the charge, use the following procedure:

- 1- Attach gauge manifolds and operate unit in cooling mode until system stabilizes (approximately five minutes).
- 2- Check each system separately with all stages operating.
- 3- Use a thermometer to accurately measure the outdoor ambient temperature.

- 4- Apply the outdoor temperature to tables 12 through 17 to determine normal operating pressures.

- 5- Compare the normal operating pressures to the pressures obtained from the gauges. Minor variations in these pressures may be expected due to differences in installations. Significant differences could mean that the system is not properly charged or that a problem exists with some component in the system. **Correct any system problems before proceeding.**

**TABLE 12  
TH 024S R22 NORMAL OPERATING PRESSURES**

| Outdoor Coil Entering Air Temp | Dis. ± 10 psig | Suct. ±5 psig |
|--------------------------------|----------------|---------------|
| 65°F                           | 226            | 147           |
| 75°F                           | 258            | 148           |
| 85°F                           | 304            | 151           |
| 95°F                           | 351            | 154           |
| 105°F                          | 402            | 157           |
| 115°F                          | 460            | 160           |

**TABLE 13  
KH 030S R410A NORMAL OPERATING PRESSURES**

| Outdoor Coil Entering Air Temp | Dis. ± 10 psig | Suct. ±5 psig |
|--------------------------------|----------------|---------------|
| 65°F                           | 235            | 145           |
| 75°F                           | 273            | 148           |
| 85°F                           | 316            | 151           |
| 95°F                           | 363            | 153           |
| 105°F                          | 416            | 156           |
| 115°F                          | 476            | 158           |

**TABLE 14  
KH R410A 036S NORMAL OPERATING PRESSURES**

| Outdoor Coil Entering Air Temp | Dis. ± 10 psig | Suct. ±5 psig |
|--------------------------------|----------------|---------------|
| 65°F                           | 247            | 140           |
| 75°F                           | 289            | 143           |
| 85°F                           | 331            | 145           |
| 95°F                           | 381            | 148           |
| 105°F                          | 434            | 151           |
| 115°F                          | 492            | 154           |

**TABLE 15  
KH 048S R410A NORMAL OPERATING PRESSURES**

| Outdoor Coil Entering Air Temp | Dis. ± 10 psig | Suct. ±5 psig |
|--------------------------------|----------------|---------------|
| 65°F                           | 272            | 139           |
| 75°F                           | 313            | 142           |
| 85°F                           | 359            | 145           |
| 95°F                           | 410            | 148           |
| 105°F                          | 465            | 150           |
| 115°F                          | 529            | 152           |

**TABLE 16**  
**KH 060S R410A NORMAL OPERATING PRESSURES**

| Outdoor Coil Entering Air Temp | Dis. $\pm$ 10 psig | Suct. $\pm$ 5 psig |
|--------------------------------|--------------------|--------------------|
| 65°F                           | 265                | 136                |
| 75°F                           | 304                | 139                |
| 85°F                           | 348                | 141                |
| 95°F                           | 397                | 144                |
| 105°F                          | 447                | 147                |
| 115°F                          | 507                | 149                |

**TABLE 17**  
**KH 072S R410A NORMAL OPERATING PRESSURES**

| Outdoor Coil Entering Air Temp | Dis. $\pm$ 10 psig | Suct. $\pm$ 5 psig |
|--------------------------------|--------------------|--------------------|
| 65°F                           | 257                | 134                |
| 75°F                           | 297                | 138                |
| 85°F                           | 340                | 142                |
| 95°F                           | 387                | 146                |
| 105°F                          | 438                | 149                |
| 115°F                          | 493                | 153                |

6- If discharge pressure is high, remove refrigerant from the system. If discharge pressure is low, add refrigerant to the system.

- Add or remove charge in increments.
- Allow the system to stabilize each time refrigerant is added or removed.

7- Use the following approach method along with the normal operating pressures to confirm readings.

**D - Charge Verification - Approach Method**

1- Using the same thermometer, compare liquid temperature to outdoor ambient temperature.

Approach Temperature = Liquid temperature minus ambient temperature.

2- Approach temperature should match values in table 18. An approach temperature greater than value shown indicates an undercharge. An approach temperature less than value shown indicates an overcharge.

3- Do not use the approach method if system pressures do not match pressures in tables 12 through 17. The approach method is not valid for grossly over or undercharged systems.

**TABLE 18**  
**APPROACH TEMPERATURE**

| Unit                 | Liquid Temp. Minus Ambient Temp. |
|----------------------|----------------------------------|
| <b>KH 024</b>        | 7°F $\pm$ 1 (3.9°C $\pm$ 0.5)    |
| <b>KH 030S, 036S</b> | 9°F $\pm$ 1 (5.0°C $\pm$ 0.5)    |
| <b>KH 048S, 060S</b> | 11°F $\pm$ 1 (6.1°C $\pm$ 0.5)   |
| <b>KH 072S</b>       | 8°F $\pm$ 1 (4.4°C $\pm$ 0.5)    |

**E - Compressor Controls**

See unit wiring diagram to determine which controls are used in each unit. Optional controls are identified on wiring diagrams by arrows at junction points.

1- Freezestat (S49)

Switch de-energizes compressor when indoor coil temperature falls below 29°F (-2°C) to prevent coil freeze-up. Switch resets when indoor coil temperature reaches 58°F (15°C).

2- Defrost Switch (S6)

Defrost switch closes to initiate defrost when liquid line temperature falls to 42°F (5.6°C). Defrost switch opens when liquid line temperature reaches 70°F (21°C) to terminate defrost. If the liquid line temperature does not rise above 70°F (21°C), the CMC1 will terminate defrost after 14 minutes. The defrost switch is located on the liquid line between the outdoor expansion valve and the distributor

3- Defrost Control (CMC1)

Defrost is liquid line temperature initiated and operates for 14 minutes unless terminated by liquid line temperature.

When the liquid line temperature drops below 42°F (5.6°C), the defrost switch closes and signals the **defrost control** that a defrost cycle is needed. If the defrost switch is still closed after 60 minutes (default), a defrost cycle begins and operates for 14 minutes. The defrost switch can terminate the defrost cycle before the 14 minutes elapses if liquid line temperature reaches 70°F (21°C)

Electric heat is energized during defrost to maintain discharge air temperature.

## Defrost Control Board

The defrost thermostat and the defrost control work together to ensure that the heat pump outdoor coil does not ice excessively during the heating mode.

### Compressor Accumulated Run-Time Interval

The defrost control will not energize a defrost cycle unless the unit has been operating in heating mode for an accumulated 60 minutes (default) on 100269-02 boards; 90 minutes (default) on 100269-04 boards. The run time interval can be changed by moving the jumper on the CMC board timing pins. See figure 18.

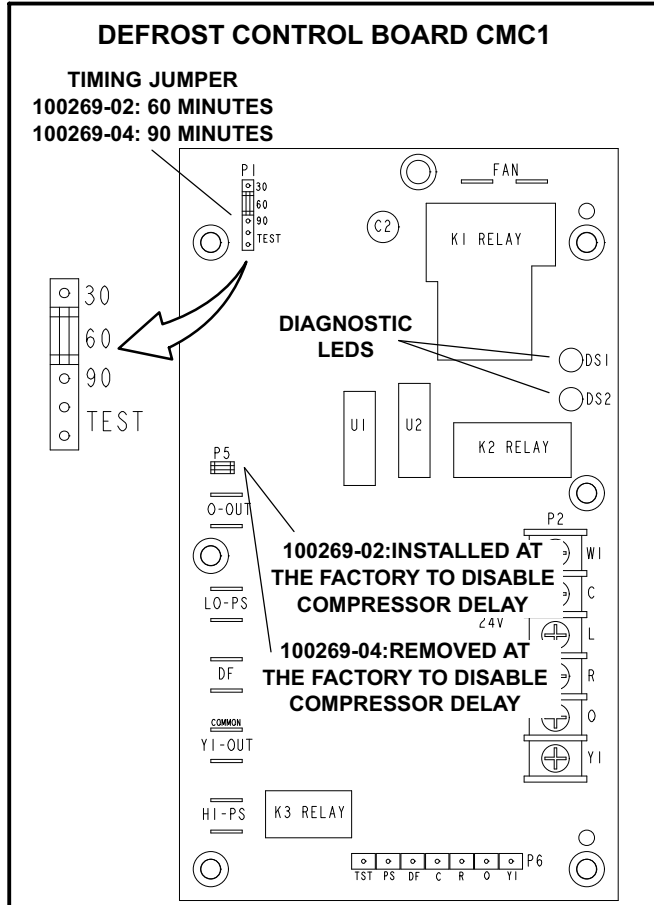

FIGURE 18

The defrost interval can be adjusted to 30, 60, or 90 minutes. The defrost timing jumper is factory-installed to provide a 60-minute defrost interval. If the timing selector jumper is not in place, the control defaults to a 90-minute defrost interval.

### Defrost Test Option

A TEST option is provided for troubleshooting. The TEST mode may be started any time the unit is in the heating mode and the defrost thermostat is closed or jumpered. If the timing jumper is in the TEST position at power-up, the defrost control will ignore the test pins. When the jumper is placed across the TEST pins for two seconds, the control will enter the defrost mode. If the jumper is

removed before an additional 5-second period has elapsed (7 seconds total), the unit will remain in defrost mode until the defrost pressure switch opens or 14 minutes have passed. If the jumper is not removed until after the additional 5-second period has elapsed, the defrost will terminate and the test option will not function again until the jumper is removed and re-applied.

### Diagnostic LEDs

The defrost board uses two LEDs for diagnostics. The LEDs flash a sequence according to the condition.

TABLE 19

| Defrost Control Board Diagnostic LED    |                         |               |
|---|-------------------------|---------------|
| Mode                                    | Green LED (DS2)         | Red LED (DS1) |
| No power to control                     | OFF                     | OFF           |
| Normal operation / power to control     | Simultaneous Slow FLASH |               |
| Anti-short cycle lockout                | Alternating Slow FLASH  |               |
| Low pressure switch, freezestat fault   | OFF                     | Slow FLASH    |
| Low pressure switch, freezestat lockout | OFF                     | ON            |
| High pressure switch fault              | Slow FLASH              | OFF           |
| High pressure switch lockout            | ON                      | OFF           |

### Service

The unit should be inspected once a year by a qualified service technician.

## ⚠ WARNING

**Product contains fiberglass wool. Disturbing the insulation in this product during installation, maintenance, or repair will expose you to fiberglass wool. Breathing this may cause lung cancer. (Fiberglass wool is known to the State of California to cause cancer.)**

**Fiberglass wool may also cause respiratory, skin, and eye irritation.**

**To reduce exposure to this substance or for further information, consult material safety data sheets available from address shown on unit nameplate or contact your supervisor.**

## ⚠ CAUTION

**Label all wires prior to disconnection when servicing controls. Wiring errors can cause improper and dangerous operation. Verify proper operation after servicing.**

### A - Lubrication

All motors are lubricated at the factory. No further lubrication is required.

## B-Compressor

If Interlink compressor replacement is necessary, call 1-800-4-LENNOX (1-800-453-6669).

### ⚠ IMPORTANT

Some scroll compressors have an internal vacuum protector that will unload scrolls when suction pressure goes below 20 psig. A hissing sound will be heard when the compressor is running unloaded. Protector will reset when low pressure in system rises above 40 psig. **DO NOT REPLACE COMPRESSOR.**

## C - Filters

Units are equipped with temporary filters which need to be replaced before the building is occupied. See table 20 for correct filter size. Refer to local codes or appropriate jurisdiction for approved filters.

Approved filters should be checked monthly and replaced when necessary. Take note of air flow direction marking on filter frame when reinstalling filters. See figure 19.

### ⚠ WARNING

Units are shipped from the factory with temporary filters. Replace filters before building is occupied. Damage to unit could result if filters are not replaced with approved filters. Refer to appropriate codes.

**TABLE 20  
UNIT FILTERS**

| Unit                     | Qty | Filter Size - inches (mm)    |
|--------------------------|-----|------------------------------|
| 024, 030, 036, 048, 060B | 4   | 16 X 20 X 2 (406 X 508 X 51) |
| 060S, 072                | 4   | 20 X 20 X 2 (508 X 508 X 51) |

*NOTE-Filters must be U.L.C. certified or equivalent for use in Canada.*

## D - Supply Air Blower Wheel

Annually inspect supply air blower wheel for accumulated dirt or dust. Turn off power before attempting to remove access panel or to clean blower wheel.

## E - Indoor Coil

Inspect and clean coil at beginning of each cooling and heating season. Clean using mild detergent or commercial coil cleanser. Flush coil and condensate drain with water taking care not to get insulation, filters and return air ducts wet.

## F - Outdoor Coil

Clean outdoor coil annually with detergent or commercial coil cleaner and inspect monthly during the cooling season.

Outdoor coils are made of single and two formed slabs. On units with two slabs, dirt and debris may become trapped between the slabs. To clean between slabs, carefully separate coil slabs and wash them thoroughly. See figure 20. Flush coils with water following cleaning.

*Note - Remove all screws and gaskets prior to cleaning procedure and replace upon completion.*

## G - Filter Drier

The unit is equipped with a biflow filter drier. If replacement is necessary, order another of like design.

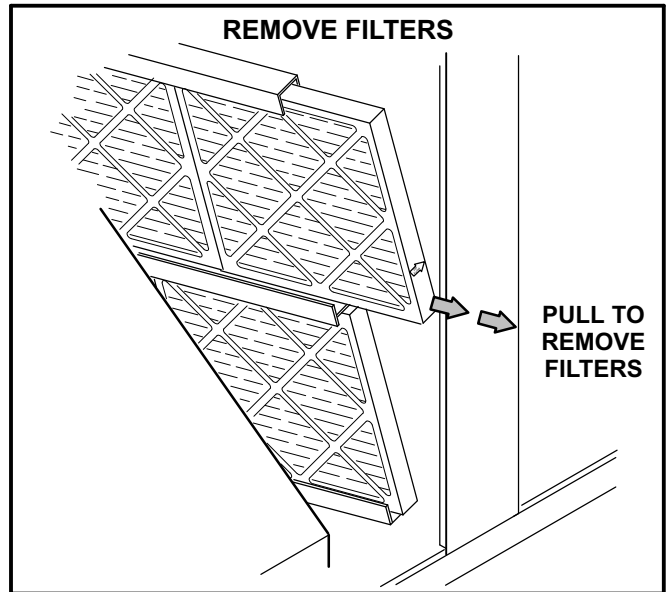

**FIGURE 19**

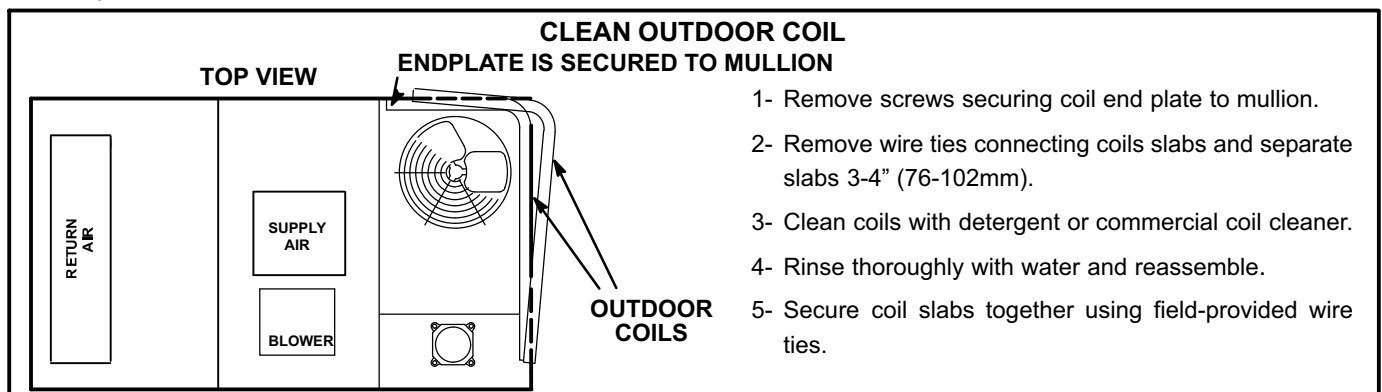

- 1- Remove screws securing coil end plate to mullion.
- 2- Remove wire ties connecting coils slabs and separate slabs 3-4" (76-102mm).
- 3- Clean coils with detergent or commercial coil cleaner.
- 4- Rinse thoroughly with water and reassemble.
- 5- Secure coil slabs together using field-provided wire ties.

**FIGURE 20**